

Jøtul F 55 V2 Carrabassett
Wood Stove

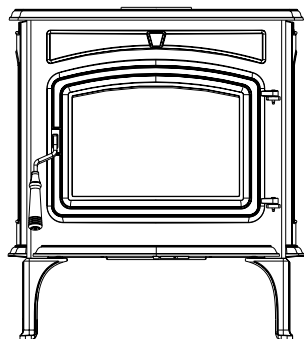

Jøtul F 55 V2 Carrabassett

Installation and Operating Instructions for
the United States and Canada

- The Jøtul F 55 V2 Carrabassett heater is listed to burn solid wood only. Do not burn any other fuels.
- Read this entire manual before you install and use this appliance.
- Save these instructions for future reference and make them available to anyone using or servicing the fireplace insert.
- This wood heater requires periodic inspection and repair for proper operation. See this manual for specific maintenance information. It is against federal regulations to operate this wood heater in a manner inconsistent with the operating instructions in this owner's manual.

This heater meets the 2020 U.S. Environmental Protection Agency's emission limits for wood heaters manufactured after May 15, 2020.



Une version française de ce manuel est disponible au téléchargement sur www.jotul.ca

Table of Contents

Accessories	2
Standards and Safety Notices	
Standards / Combustion Specifications / Codes	3
Safety Notices	4
1.0 Installation	
1.1. Pre-installation Assembly	5
1.2. Flue Collar Installation	5
1.3. Flue Collar Heat Shield	5
1.4. Short Leg Kit	6
1.5. Leg Levellers	6
1.6. Chimney Connector	6
2.0 Chimney Requirements	
2.1. Masonry Chimneys	7
2.2. Prefabricated Chimneys	7
2.3. Chimney Height	8
2.4. Wall Pass-Throughs	8
3.0 Connecting to the Chimney	
3.1. Masonry Chimneys	9
3.2. Hearthmount into a Masonry Fireplace	9
3.3. Prefabricated Chimneys	10
3.4. Mobile Home Requirements	10
4.0 Clearances to Combustibles	
4.1. Floor Protection	11
4.2. Clearances to Walls and Ceilings	11
4.3. Using Shields to Reduce Clearances	11
4.4. Alcove Installation	12
4.5. Fireplace Clearances, Mantel and Trim	12
4.6. Clearance Diagrams	13
5.0 Operation	
5.1. Combustion Efficiency	14
5.2. CO Emissions	14
5.3. Wood Fuel and Performance	14
5.4. How Your F 55 Works	15
5.5. Controlling the Fire	15
5.6. Air Control / Blower Settings	15
5.7. Break-in Procedure	16
5.8. Starting and Maintaining the Fire	16
5.9. Adding Fuel	17
5.10. Creosote and the Need for Removal	17
5.11. Ash Removal	18
6.0 Maintenance	
6.1. Door Latch	18
6.2. Glass Care	18
6.3. General Care	19
6.4. Gasket Replacement	19
6.5. Glass Replacement	19
6.6. Chimney System	19
7.0 Appendix	
7.1. Blower Installation	20
7.2. Outside Air Kit Installation	22
7.3. Short Leg Kit Installation	22
7.4. Mobile Home Floor Bracket	23
7.5. Alternate Floor Protection	23
7.6. Secondary Air Manifold Maintenance	24
7.7. F55 V2 Start-Up and Refueling	25
8.0. Illustrated Part List	26
9.0. Warranty Statement	28

Installation and Operation Instructions for USA/Canada

Safety Notice: If this solid fuel room heater is not properly installed, a house fire may result. For your safety, follow the installation directions. Contact local building or fire officials about restrictions and installation inspection requirements in your area. Save these instructions for future reference.

Accessories

Stove Gloves, pair - #157363

Heavy-duty, flame-retardant with full gauntlet

Stove-Top Thermometer - #5002

We recommend the use of a magnetic stove-top thermometer to monitor the surface temperature of the stove. The optimum surface temperature range for the most efficient performance is between 400° F - 700° F (205° C - 316° C).

Outside Air Manifold - #158208

This kit includes a plenum assembly which attaches to the stove bottom. It permits connection of duct work from an outside source directly to the air intake of the stove. A direct outside air connection is required for mobile home installations. *This kit cannot be used with the Short Leg Kit.*

Mobile Home Floor Bracket Kit - #157321

This kit includes two brackets used to fulfill the mobile home requirement that the stove be secured directly to the floor.

Blower Kit - #156431

This kit includes components for mounting a thermostatically controlled 120 cfm blower to the back of the stove to enhance heat convection into the living area.

Gasket Kit - #157680

Includes enough gasket material to replace the glass and door seals.

Short Leg Kit - #158209

This kit includes four, 4 1/4" (108 mm) steel legs and a Bottom Heat Shield which allow stove installation into a fireplace opening height as low as 27 1/4". **Approved only for code-approved, masonry fireplace hearth mount installation.**

Standards

The Jøtul F 55 V2 Carrabassett solid fuel heater has been tested and listed to:

U.S: ANSI/UL 1482-2011

Canada: CAN/ULC-S627-00 and ULC-S628-93

Certified Safety Tests performed by:

ITS, Intertek Testing Services

Middleton, WI

Manufactured by:

Jøtul North America

55 Hutcherson Drive

Gorham, Maine 04038-2644

Combustion Specifications

Jøtul F 55 V2 Carrabassett

Heat Output Range: ¹	18,962 to 84,311 BTU/hr.	Heating Capacity: ²	Up to 2,300 sq. ft.
Maximum Burn Time: ²	Up to 10 hours	Combustion Efficiency: ³	HHV: 67.97% LHV: 73.13 %
CO Emissions: ⁴	1.06 g/min	Particulate Emissions: ⁵	1.31 g/hr - Cord WoodFuel:
Up to 18" Logs (457 mm)	Loaded Front-to-Back		

See the Operation section of this manual for important information regarding the safe, proper, and most efficient operation of your stove.

¹ **Heat Output Range** results are determined during specific emissions tests established by the EPA.

Maximum Heat Output value is representative of a more frequent re-fueling cycle than specified in the EPA High Heat Output test method.

² **Heating Capacity and Maximum Burn Time** will vary depending on design of home, climate, wood type and operation

³ **High Heat Value and Low Heat Value** are obtained per CSA B415.1-10 test method. HHV calculation encompasses all products of combustion, including H₂O condensation. Simply put, HHV assumes all the water component is in a liquid state (condensed) at the end of combustion and that heat recovered from condensation can be put to use. LHV efficiency calculation does not consider heat recovered from water vapor condensation.

⁴ **Carbon Monoxide Emissions** rate results from Test Method CSA B415.1-10.

⁵ **Particulate Emissions** rate is obtained using EPA test methods:

ALT-125 (Cordwood Fuel)

ASTM E2515-11

ASTM E3053-17

WARNING !

THIS WOOD HEATER HAS A MANUFACTURER-SET MINIMUM LOW BURN RATE THAT MUST NOT BE ALTERED. IT IS AGAINST FEDERAL REGULATIONS TO ALTER THIS SETTING OR OTHERWISE OPERATE THIS WOOD HEATER IN A MANNER INCONSISTENT WITH OPERATING INSTRUCTIONS IN THIS MANUAL.

Check Building Codes

When installing, operating and maintaining your Jøtul F 55 V2 Carrabassett woodstove, follow the guidelines presented in these instructions, and make them available to anyone using or servicing the stove.

Your city, town, county or province may require a building permit to install a solid fuel burning appliance.

For installation requirements not specifically addressed in this manual, refer to the standards listed below:

In the U.S., the National Fire Protection Association's Code, NFPA 211, *Standards for Chimneys, Fireplaces, Vents and Solid Fuel Burning Appliances*, or similar regulations, may apply to the installation of a solid fuel burning appliance in your area.

In Canada, the guideline is established by the CSA Standard, CAN/CSA-B365-M93, *Installation Code for Solid-Fuel-Burning Appliances and Equipment*.

Always consult your local building inspector or authority having jurisdiction to determine what regulations apply in your area.

The Jøtul F 55 V2 Carrabassett is approved for use in mobile homes. Install in accordance with 24 CFR, Part 3280 (HUD). Follow the instructions in this manual.



We suggest that our woodburning hearth products be installed and serviced by professionals who are certified in the U.S. by the National Fireplace Institute® (NFI) as NFI Woodburning Specialists or who are certified in Canada by Wood Energy Technical Training (WETT).



Safety Notices

- **BURN SOLID, NATURAL WOOD FUEL ONLY. DO NOT BURN ANY OTHER FUEL.**
- **DO NOT USE CHEMICALS OR FLUIDS TO START A FIRE. DO NOT BURN GARBAGE OR FLAMMABLE FUELS.**
- **DO NOT USE A GRATE OR ELEVATE THE FIRE. BUILD THE FIRE DIRECTLY ON THE HEARTH.**
- **IF THIS ROOM HEATER IS NOT PROPERLY INSTALLED, A HOUSE FIRE MAY RESULT. TO REDUCE THE RISK OF FIRE, FOLLOW THE INSTRUCTIONS IN THIS MANUAL. FAILURE TO FOLLOW THESE INSTRUCTIONS MAY RESULT IN PROPERTY DAMAGE, BODILY INJURY, OR LOSS OF LIFE.**
- **CONTACT LOCAL BUILDING OR FIRE OFFICIALS ABOUT RESTRICTIONS AND INSTALLATION INSPECTION REQUIREMENTS IN YOUR AREA.**
- **ANY EXISTING CHIMNEY SYSTEM MUST BE INSPECTED BEFORE INSTALLATION OF THIS APPLIANCE.**
- **DO NOT CONNECT THIS STOVE TO ANY AIR DISTRIBUTION DUCT OR SYSTEM.**
- **EXTREMELY HOT WHILE IN OPERATION! KEEP CHILDREN, CLOTHING, AND FURNITURE AWAY. CONTACT WILL CAUSE SKIN BURNS. USE A CHILD GUARD SCREEN TO PREVENT ACCIDENTAL CONTACT BY SMALL CHILDREN.**
- **INSTALL SMOKE DETECTORS IN THE LIVING AREA AND BEDROOMS OF YOUR HOME. TEST THEM REGULARLY AND INSTALL FRESH BATTERIES TWICE ANNUALLY.**
WHEN INSTALLED IN THE SAME ROOM AS THE STOVE, A SMOKE OR CARBON MONOXIDE DETECTOR SHOULD BE LOCATED AS FAR FROM THE STOVE AS POSSIBLE TO PREVENT THE ALARM SOUNDING WHEN ADDING FUEL.
- **Avoid creating a low pressure condition in the room where the stove is operating. Be aware that operation of an exhaust fan or clothes dryer can create a low pressure area and consequently promote flow reversal through the stove and chimney system. In some cases, the optional Outside Air Kit #158208 can be used to alleviate this condition. The chimney and building, however, always work together as a system - provision of outside air, directly or indirectly to an atmospherically vented appliance will not guarantee proper chimney performance. Consult your local Jøtul authorized dealer regarding specific installation/performance issues.**
- **Jøtul strongly recommends that this stove be installed by a professional solid fuel technician, or that you consult one if you do the work yourself. Also, consult your insurance company regarding any other specific requirements.**

Installation Tools Required, but not limited to:

- Measuring Tape
- Phillips screwdriver
- 10 mm open-end or socket wrench
- Work Gloves
- Safety Glasses
- 4 mm hex key

PLEASE NOTE:

IT IS NORMAL FOR SMOKE AND ODOR TO OCCUR DURING THE INITIAL STAGES OF OPERATION, DEPENDING UPON TEMPERATURES GENERATED OVER TIME. THIS “CURING” CONDITION CAN BE ALLEVIATED BY PROMOTING FRESH AIR CIRCULATION WITHIN THE IMMEDIATE VICINITY OF THE APPLIANCE.

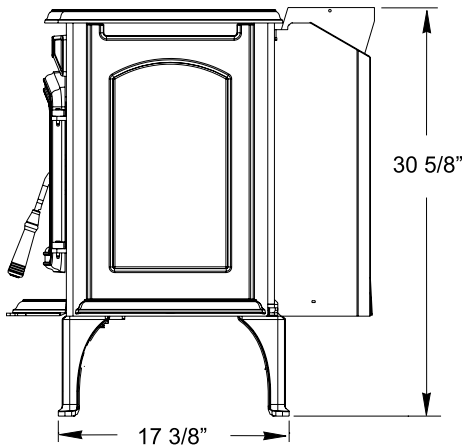
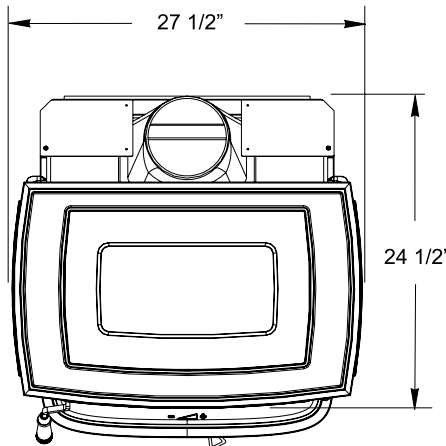
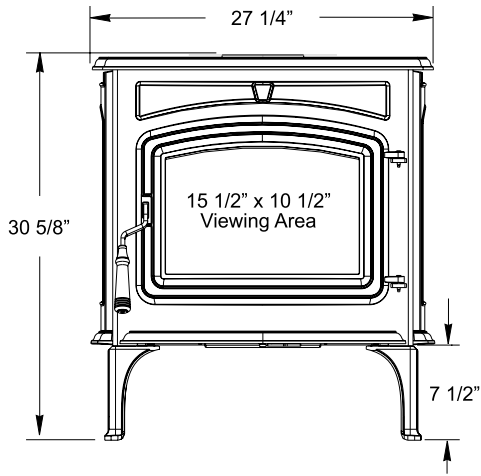

Top Exit
Flue Collar

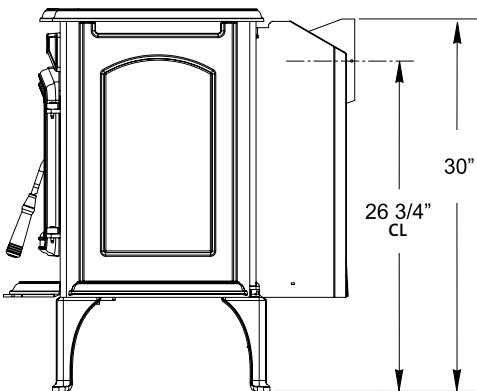

Rear Exit
Flue Collar

1.0 Pre-installation Assembly

1.1 Unpack the Stove

Inspect the stove for damage. Contact your dealer immediately if any damage is found. Do not install the stove if any damage is evident. Contact your dealer.

Contents:

- Flue Collar Heat Shield
- #8 x 12 mm sheet metal screws, 4
- Leg Leveller Screws, 2

NOTE: The integral Rear Shroud acts as a heat shield. There is no accessory rear heat shield.

1.2 Flue Collar Orientation

The Flue Collar is oriented in the Top Exit position. To change orientation to Rear Exit:

1. Twist and remove the perforated cut-out section from the top edge of the rear shroud.
2. While holding the M6 flange nuts on the inside of the flue collar, to keep them from falling into the stove, use a 10 mm open end wrench or socket wrench to remove the two M6 x 20 bolts that attach the flue collar to the stove. Orient the flue collar to the rear and use the same hardware to re-attach it to the stove.

1.3 Flue Collar Heat Shield

Not applicable for rear exit configuration.

1. Fold the heat shield on the perforations to conform to the shape as illustrated in fig.2.
2. Secure it to the rear stove shroud using the four #8 x 12 sheet metal screws from the hardware bag.

1.4 Optional Accessories

Follow the instructions provided with those kits or in this manual.

NOTE!

- The Outside Air Manifold cannot be installed with Short Legs.
- Install the optional Blower Kit BEFORE installing the Short Legs.
- Short Legs may be installed only on a code approved hearthmount installation.

1.5 Leg Levellers

Two leg leveller screws are included in the hardware bag. Install the screws in the appropriate legs BEFORE locating the stove in the final position. See fig. 25, page 23 for Mobile Home Kit installation.

1.6 Chimney Connector

Use 6" single wall or listed 6" double-wall stovepipe to connect the stove to the chimney. Single wall stovepipe must be black steel or stainless steel and have a minimum thickness of 24 gauge. Do not use aluminum or galvanized steel pipe for chimney connection - these materials are not suitable for use with solid fuel. Attach the flue collar to the chimney connection using 2 self-drilling screws found in the miscellaneous kit.

Follow these guidelines:

- Do not use chimney connector as a chimney. It is intended only as a connection device.
- Each connector section must be oriented with the male (crimped) end pointing toward the stove. See fig. 3.
- Secure all connector joints with three sheet metal screws.
- For the best performance, the chimney connector should be as short and direct as possible, including no more than two 90° elbows.
- The maximum vertical run of single wall stovepipe should not exceed 10 ft.
- The maximum horizontal run should not exceed 3 ft. with a 1/4" rise per foot. Under no circumstance should horizontal pipe be allowed to slant down toward the chimney.
- No part of the chimney connector may pass through an attic or roof space, closet or other concealed space, or through a floor or ceiling. All sections of the chimney connectors must be accessible for cleaning. Where passage through a wall or partition of combustible construction is desired, the installation must conform with NFPA 211 or CAN/CSA-B365, and is also addressed in this manual.
- Do not connect this stove to a chimney flue serving another appliance.

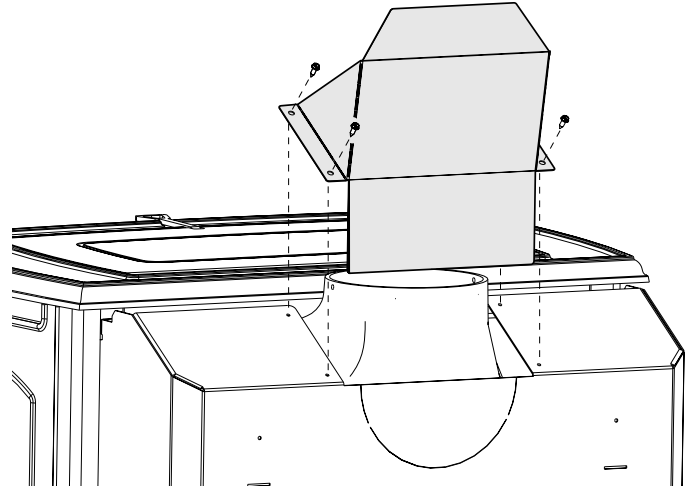

Figure 2. Flue Collar heat shield attachment.

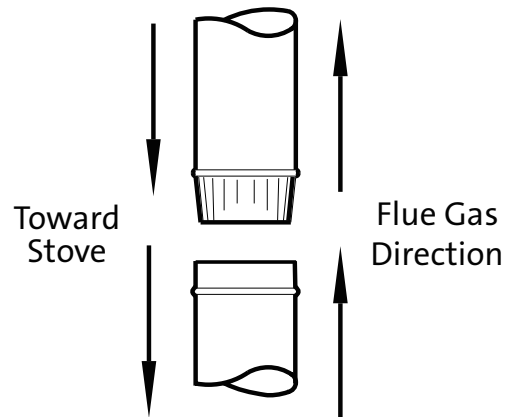

Figure 3. Chimney connector orientation.

2.0 Chimney Requirements

There are two types of approved chimneys:

1. A code-approved masonry chimney with a ceramic tile or listed steel flue liner.
2. A prefabricated chimney complying with the requirements for Type HT (2100°F) chimneys per UL 103 or ULC S629.

Use of an existing chimney requires that the entire system pass a UL 1482 Level II inspection by a qualified solid fuel technician or building official.

The chimney size should not be less than the cross-sectional area of the flue collar, and not more than three times greater than the cross-sectional area of the flue collar. If the chimney flue is outdoors, its cross-sectional area may not exceed two times greater than the stove flue collar. See also Sect. 3.2.

When selecting a chimney type and the location for the chimney in the house, keep this in mind: It is the chimney that makes the stove work - not the stove that makes the chimney work. This is because a chimney actually creates a suction, called "draft" which pulls air through the stove.

Several factors affect draft: chimney height, cross-sectional area (size), and temperature of the chimney, as well as the proximity of surrounding trees or buildings.

A short exterior masonry chimney will give the poorest performance because it will be difficult to warm the flue and sustain the temperatures necessary to maintain draft strength. In extremely cold climates, it may be necessary to reline the chimney or extend the height to help establish draft.

A tall, interior masonry chimney is easier to keep warm and will perform the best under a variety of weather and environmental conditions.

The following guidelines give the necessary chimney requirements based on the national code (ANSI-NFPA 211 for the U.S. And CSA CAN-B365 for Canada). However, many local codes differ from the national code to take into account climate, altitude, or other factors. Your local building inspector is the final approving authority. Consult them prior to installation.

Do not connect the stove to any air distribution duct or system.

2.1 Masonry Chimneys

Follow these guidelines when installing the Jøtul F 55 V2 into a masonry fireplace:

- The masonry chimney must have a fireclay liner or equivalent, with a minimum thickness of 5/8" and must be installed with refractory mortar. There must be at least 1/2" air space between the flue liner and chimney wall.
- The fireclay flue liner must have a nominal size of 8" X 8", and should not be larger than 8"X 12". A round fireclay liner must have a minimum inside diameter of 6" and maximum inside diameter of 8". A larger chimney should be relined with an appropriate code approved liner.
- Brick or modular block must be a minimum of 4" nominal thickness. Stone construction must be at least 12" thick.
- A newly-built chimney must conform to local codes, or, in their absence, must comply with national regulations.
- An existing chimney must be inspected by a professional, licensed chimney sweep, fire official, or code officer to ensure that the chimney is in proper working order. Any repairs must be completed before installing the stove.
- No other appliance may be vented into the same flue.
- An airtight clean-out door should be located at the base of the chimney.

2.2 Prefabricated Chimneys

A prefabricated metal chimney must be tested and listed for use with solid fuel burning appliances. High Temperature (HT) Chimney Standard UL 103 for the U.S. and High Temperature Standard ULC S-629 for Canada.

The manufacturer's installation instructions must be followed precisely. Always maintain the proper clearance to combustibles as established by the pipe manufacturer. This clearance is usually a minimum of 2", although it may vary by manufacturer or for certain chimney components.

2.3 Chimney Height

The Jøtul F 55 V2 woodstove requires a minimum chimney height of 15 feet. The chimney must be at least 3 feet higher than the highest point where it passes through the roof and at least 2 feet higher than the highest part of the roof or structure that is within 10 feet of the chimney, measured horizontally. See fig. 4.

Chimneys shorter than 14 feet (4.27 m) may not provide adequate draft. Inadequate draft can result in smoke spillage when loading the stove, or when the door is open. Poor draft can also cause back puffing (ignition of gas build-up inside the firebox) and sluggish performance. The minimum height does not, in itself, guarantee proper chimney performance. Optimum draft force should be in the .05 - .10 in. w.c. range measured by a Magnahelic gauge. Draft at .07 w.c. is ideal.

Excessive chimney height can promote over-strong draft resulting in high stove temperatures and short burn times. Your Jøtul dealer is an expert resource to consult regarding draft issues or other performance-related questions.

2.4 Wall Pass-Throughs

Note: In addition to the methods described here, any listed, prefabricated wall pass-through components available from chimney manufacturers may be used.

In the U.S.

The National Fire Protection Association's publication, NFPA 211, *Standard for Chimneys, Fireplaces, Vents and Solid Fuel Burning Appliances* permits four methods for passing through a combustible wall. Before proceeding with any method, be sure to consult with your local building officials to discuss any local code requirements.

Common Method:

See fig. 5. Remove all combustible materials from the pass-through area (around the chimney connector), a minimum 12". A 6" diameter connector will require a 31" x 31" square opening.

The opening must be filled with at least 12" of brick around a fireclay liner. The liner must be ASTM C35 or equivalent, having a minimum wall thickness of 5/8".

The Pass-through must be at least 18" from combustible ceiling materials.

It will be necessary to cut wall studs, install headers, and construct a sill frame to maintain the proper dimensions and to support the weight of the brick.

The bricks must be solid brick with a minimum of 3 inches thick (nominal 4").

Refractory mortar must be used at the junction of the chimney and the pass-through liner. The pass-through liner must

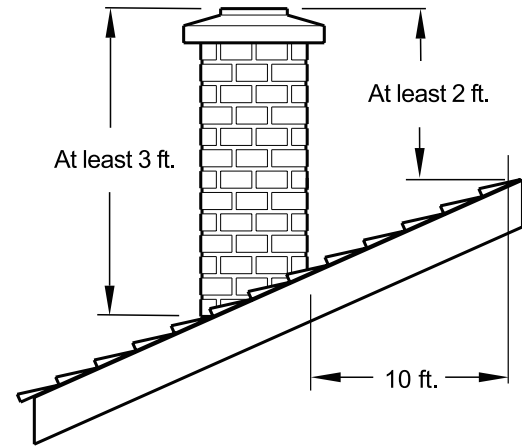

Figure 4. Chimney Height Requirement.

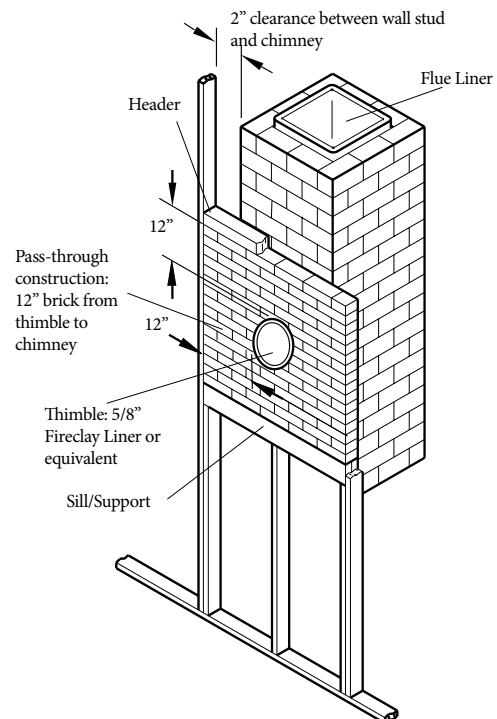

Figure 5. Masonry Wall Pass-through.

not penetrate the chimney liner beyond the inner surface of the chimney liner. Use extreme care when constructing the hole in the chimney liner as the tiles can shatter easily.

In Canada

The installation must conform to CAN/CSA-B365, *Installation Code for Solid Fuel Burning Appliances and Equipment*. Before proceeding be sure to consult your local building inspector.

Common Method:

This method requires the removal of all combustible materials from at least 18" around the chimney connector's proposed location. A 6" round liner requires a minimum opening 43" x 43" square.

Locate the pass-through at least 18" from combustible ceiling materials.

The space that is cleared of combustible materials must remain empty. Sheet metal panels can be used to cover the area. However, when using a panel on both sides of the wall, each cover must be installed on noncombustible spacers at least 1" from the wall. If one panel of sheet metal is to be used it may be installed flush to the wall.

See section 5.3.1 and 5.3.2 of CAN/CSA - B365-M91. Consult your local building inspector, authorized Jøtul Dealer, NFPA 211 in the U.S. or CAN/CSA-B635 in Canada for other approved wall pass-through methods.

3.0 Connecting to the Chimney

3.1 Masonry Chimney

When installing a Jøtul F 55 V2 into a masonry chimney through a "thimble" (the opening through the chimney wall to the flue), the thimble must consist of ceramic tile or steel and be securely cemented in place.

The chimney connector/stove pipe must slide completely inside the thimble to the inner surface or the flue liner. It may be necessary to make use of a thimble sleeve (a pipe with a slightly smaller diameter than standard stove pipe). See fig. 6.

The connector pipe or thimble sleeve must not protrude into the flue liner or otherwise restrict draft.

Use refractory cement to seal the seam between the chimney connector, sleeve, and thimble.

Do not connect this stove to a chimney flue servicing another appliance of any kind.

3.2 Hearthmount into a Masonry Fireplace

The Jøtul F 55 V2 may be installed into a masonry fireplace with a minimum opening height of 30 1/2" for standard legs.

Use Short Leg Kit #158209 to install into a fireplace with a minimum opening height of 27 1/4". *Short legs are approved only for use on a code-approved, masonry fireplace hearth. The Outside Air Kit cannot be used with the Short Leg Kit. The Bottom Heat Shield must be used with the Short Leg Kit.*

Building code requires that the fireplace damper plate be removed or securely fixed in the open position.

A connector pipe must then extend from the stove's flue exit through the damper area of the fireplace and into the chimney tile liner. See fig. 7. In any case, we recommend that a full liner be installed through any masonry chimney to

ensure good performance.

The cross-sectional area of the flue of a chimney with no walls exposed to the outside below the roofline may be no more than three times the cross-sectional area of the stove flue collar.

The cross-sectional area of the flue of a chimney with one or more walls exposed to the outside below the roofline may be no more than two times the cross-sectional area of the stove flue collar.

If the chimney liner is too large to accommodate the stove, an approved relining system must be installed to resize the flue.

A new sheet metal damper block-off plate must be installed around the connector pipe at the damper frame and sealed with the proper sealant (usually High-Temp Silicone).

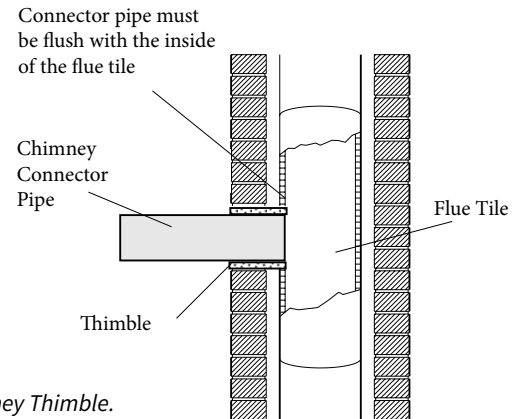

Figure 6..
Masonry Chimney Thimble.

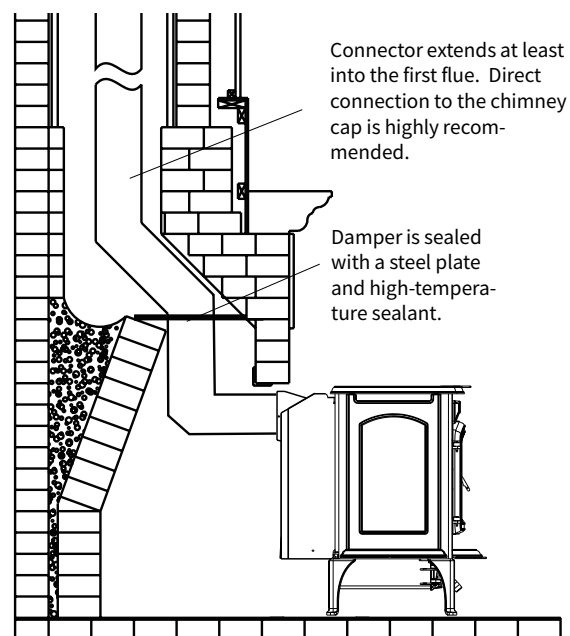

Figure 7. Hearthmount Installation.

3.3 Prefabricated Chimneys

When connecting the Jøtul F 55 V2 to a prefabricated metal chimney always follow the pipe manufacturer's instructions and be sure to use the all components that are required. This usually includes a chimney adaptor that is secured to the bottom section of the metal chimney and allows the chimney pipe to be secured to it with two sheet metal screws. See fig. 8.

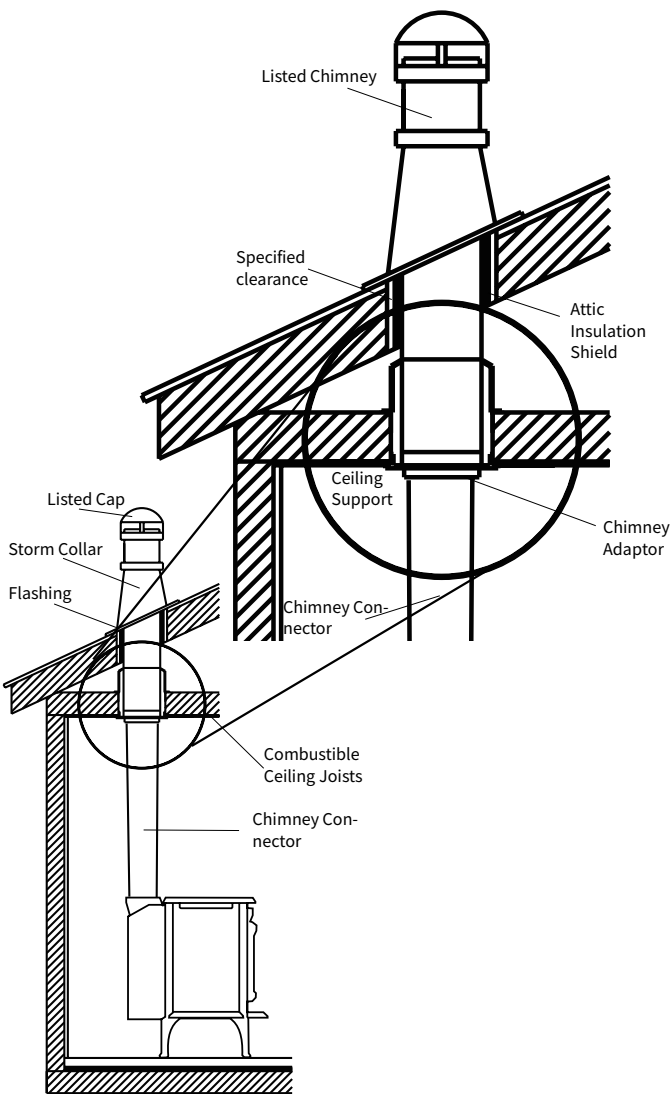

Figure 8. Prefabricated Listed Type HT Chimney.

3.4 Mobile Home Installation

The Jøtul F 55 V2 is approved for installation in manufactured mobile homes provided the following requirements are met:

1. All chimney components, including chimney sections, supports, spark arrestor, etc., shall comply with the Standard for Factory-built Chimneys for Residential Type and Building Heating Appliances, UL 103 and/or CAN/ULC-S629 Standard for 650°C Factory-built Chimneys.
2. The chimney shall be attached directly to the stove and extend at least 3 ft. above the roof. Termination must be at least 2 ft. (0.6m) above the highest elevation of any part of the mobile home within 10 ft..
3. In order to allow for transportation of the mobile home, the chimney termination shall be readily removed at or below an elevation of 13.5 ft. above ground level and reinstalled without use of special tools or instructions.
4. A spark arrestor must be installed at the termination. The net free area of the arrester above the chimney outlet must not be less than four times the net area of the chimney outlet, and the vertical height of the arrester must not be less than one-half the diameter of the chimney flue. Openings shall not permit the passage of a sphere having a diameter larger than 1/2", and shall permit the passage of a sphere having a diameter of 3/8".
5. Direct connection of the stove to an outside air source is required. Use Outside Air Kit #158208. Do not substitute any other connection method or device. See Appendix, Section 7.0. Duct termination must not be installed at a level that is higher than the air inlet located at the bottom of the stove.
6. The stove must be secured to the mobile home floor. Use Floor Bracket Kit 157321. See fig. 25, pg. 23.
7. When the chimney exits the mobile home at a location other than through the roof and exits at a point 7 ft. or less above the ground level, a guard or other method of enclosing the chimney must be provided at the point of exit for a height up to 7 ft. Openings of this chimney guard shall not permit penetration of a 3/4 in. diameter rod or contact with the chimney by a 1/2 inch diameter rod inserted through the opening a distance of 4 inches.
8. Provision must be made for electrical grounding of the chimney, chimney connector, and stove in accordance with local building codes.

WARNING: Do not install this appliance in a sleeping room.

CAUTION: The structural integrity of the mobile home floor, walls, and ceiling/roof must be maintained.

4.0 Clearance to Combustibles

4.1 Floor Protection

The Jøtul F 55 V2 requires one of the following forms of hearth protection if not installed directly on concrete poured on earth:

- 1) Any UL, ULC, or Warnock Hersey Listed Type 1 hearth board.
- 2) Any non-combustible material.

No Bottom Heat Shield is required in either case unless using Short Leg Kit #158209. *Short legs are approved only for use on a code-approved, masonry fireplace hearth.*

IN THE U.S.: Floor protection must extend continuously forward from the door opening at least 16 in. and 8 in. from the sides of the door opening. Protection must also extend 2 in. under the chimney connector. This will result in a minimum floor protector 33" wide x 40 3/4" deep. See fig 9.

IN CANADA: Floor protection must extend continuously 18" from the front of the stove and 8 in. from the sides *and rear*. It must also extend 2 in. under the chimney connector. This results in a floor protector 43 1/2 in. x 50 1/2 in. See fig.10.

4.2 Clearances to Walls and Ceilings

The clearances listed and diagramed in this manual have been tested to UL and ULC standards and are the minimum clearances to combustible materials specifically established for the Jøtul F 55 V2.

A combustible surface is anything that can burn (i.e. sheet rock, wall paper, wood, fabrics etc.). These surfaces are not limited to those that are visible and also include materials that are behind noncombustible materials.

If you are not sure of the combustible nature of a material, consult your local fire officials.

Remember: "Fire Resistant" materials are considered combustible; they are difficult to ignite, but will burn. Also "Fire-rated" sheet rock is also considered combustible.

Contact your local building officials about restrictions and installation requirements in your area.

See pages 12-13 for clearance requirements and diagrams.

4.2.1 Alternate Floor Protection

All floor protection materials must be non-combustible (i.e., metals, brick, stone, mineral fiber boards, etc.). Any organic materials (i.e., plastics, wood, paper products, etc.) are combustible and must not be used. Local codes may specify some form of thermal designation such as R-value (thermal resistance), k-factor (thermal conductivity), or C-factor (thermal conductance).

See 7.4 Appendix for the procedure to determine alternate floor protection materials that meet the thermal requirements for this stove.

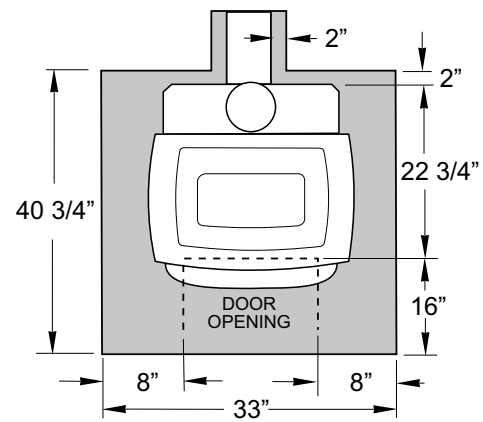

Figure 9. Floor Protection minimum dimensions, U.S.

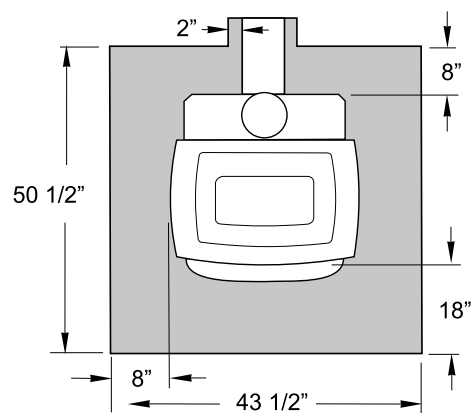

Figure 10. Floor Protection minimum dimensions, Canada.

4.3 Using Shields to Reduce Clearances

Double Wall Connector: Listed double wall pipe is an acceptable alternative to connector pipe heat shields.

Wall-Mounted Protection: When reducing clearances through the use of wall-mounted protection:

In the U.S. refer to NFPA 211, Standard for Chimneys, Fireplaces, Vents and Solid Fuel Burning Appliances, for acceptable materials, proper sizing and construction guidelines.

In Canada, refer to CAN/CSA-B365, Installation Code for Solid-Fuel Burning Appliances and Equipment, also for acceptable materials, proper sizing and construction guidelines.

Notice: Many manufacturers have developed woodstove accessories that permit clearance reduction. Use only those accessories that have been tested by an independent laboratory and carry the laboratory's testing mark. Be sure to follow all of the manufacturer's instructions.

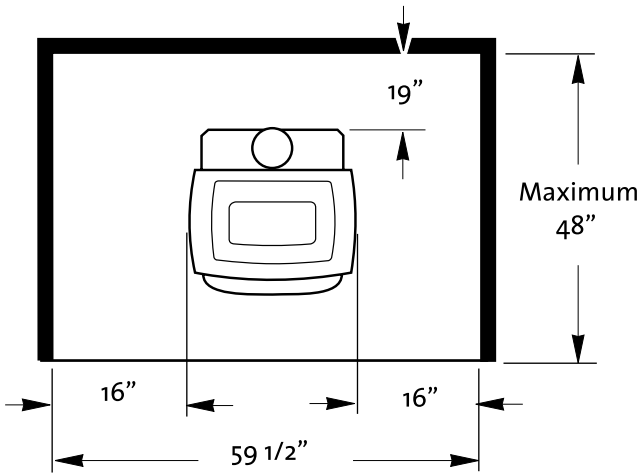

Figure 11. Alcove with Unprotected Walls.

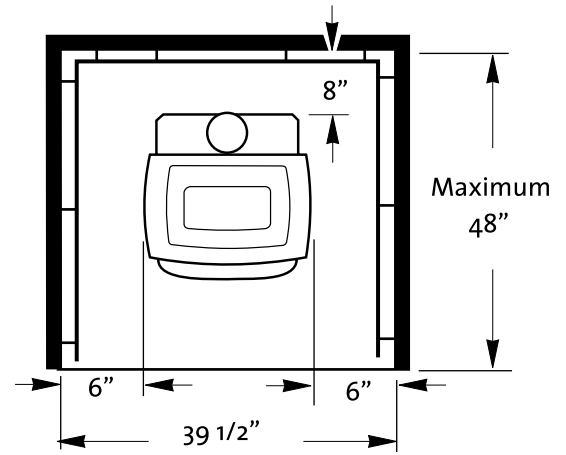

Figure 12. Alcove with Wall Protection.

4.4 Alcove Installation

The Jøtul F 55 V2 can be installed in an alcove as diagrammed in figs. 11.-12.

1. The stove must be installed only with double-wall chimney connector.
2. Wall and ceiling protection, if used, must extend over the entire area.
3. Alcove floor protection must consist of a UL/ULC or WHI listed hearth pad or a non combustible material.
4. Minimum Alcove Ceiling Height:
 Unprotected Surface - 72"
 Protected Surface - 59"

The Short Leg option is not approved for use in Alcove installations.

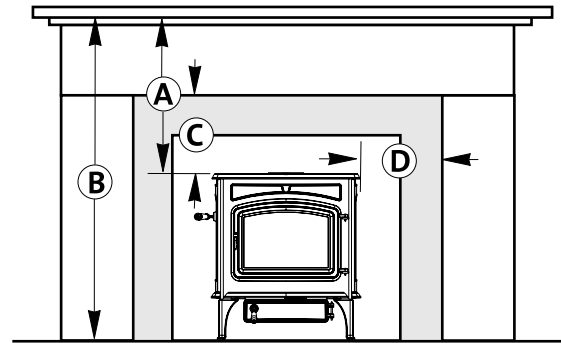

- A: Unit to Mantel (12 in. deep)- 35 in.
- B: Floor to Mantel- 66 in.
- C: Stove to 1 in. Top Trim - 31 in.
- D: Stove to 1 in. Side Trim - 14 in.

Figure 13. Mantel and Triim Clearances.

4.5 Clearances to Fireplace Mantels and Surrounding Trim

See fig. 13 and the Clearance Chart on page 12 for approved clearances to combustible materials that may be part of fireplace construction.

Mantel and Trim clearances may be reduced by 50% with use of shielding constructed in accordance with NFPA 211 specifications.

4.6 Jøtul F 55 V2 Carrabassett Clearance Specifications

	UNPROTECTED WALLS					PROTECTED WALLS PER NFPA211 OR CAN/CSA- B365-M93				
	SIDE	REAR	CORNER	CORNER TO FRONT FLOOR PROTECTION**	FRONT FLOOR PROTECTION WIDTH**	SIDE	REAR	CORNER	CORNER TO FRONT FLOOR PROTECTION**	FRONT FLOOR PROTECTION WIDTH**
Single Wall Connector	A 14"	B 18"	C 12"	N US: 66 1/8" CAN: 68 1/8"	S US: 32 7/8" CAN: 43 1/2"	C 12"	D 8"	E 7 1/2"	O US: 59 3/4" CAN: 61 3/4"	U US: 32 7/8" CAN: 43 1/2"
Single Wall Connector w/Flue Collar Heat Shield	F 16"	G 10"	H 11"	P US: 64 3/4" CAN: 66 3/4"	S US: 32 7/8" CAN: 43 1/2"	D 8"	I 5"	I 5"	Q US: 56 1/4" CAN: 58 1/4"	U US: 32 7/8" CAN: 43 1/2"
Double Wall Connector	A 14"	J 9"	C 12"	N US: 66 1/8" CAN: 68 1/8"	S US: 32 7/8" CAN: 43 1/2"	K 6"	D 8"	I 5"	Q US: 56 1/4" CAN: 58 1/4"	U US: 32 7/8" CAN: 43 1/2"
Double Wall Connector w/Flue Collar Heat Shield	A 14"	K 6"	C 12"	N US: 66 1/8" CAN: 68 1/8"	S US: 32 7/8" CAN: 43 1/2"	I 5"	K 6"	L 2.5"	R US: 52 3/4" CAN: 54 3/4"	U US: 32 7/8" CAN: 43 1/2"

**US and CAN measurements are not the same and are not interchangeable.

Figure 14. Clearance Diagrams. All specifications applicable to both top and rear exit configurations.

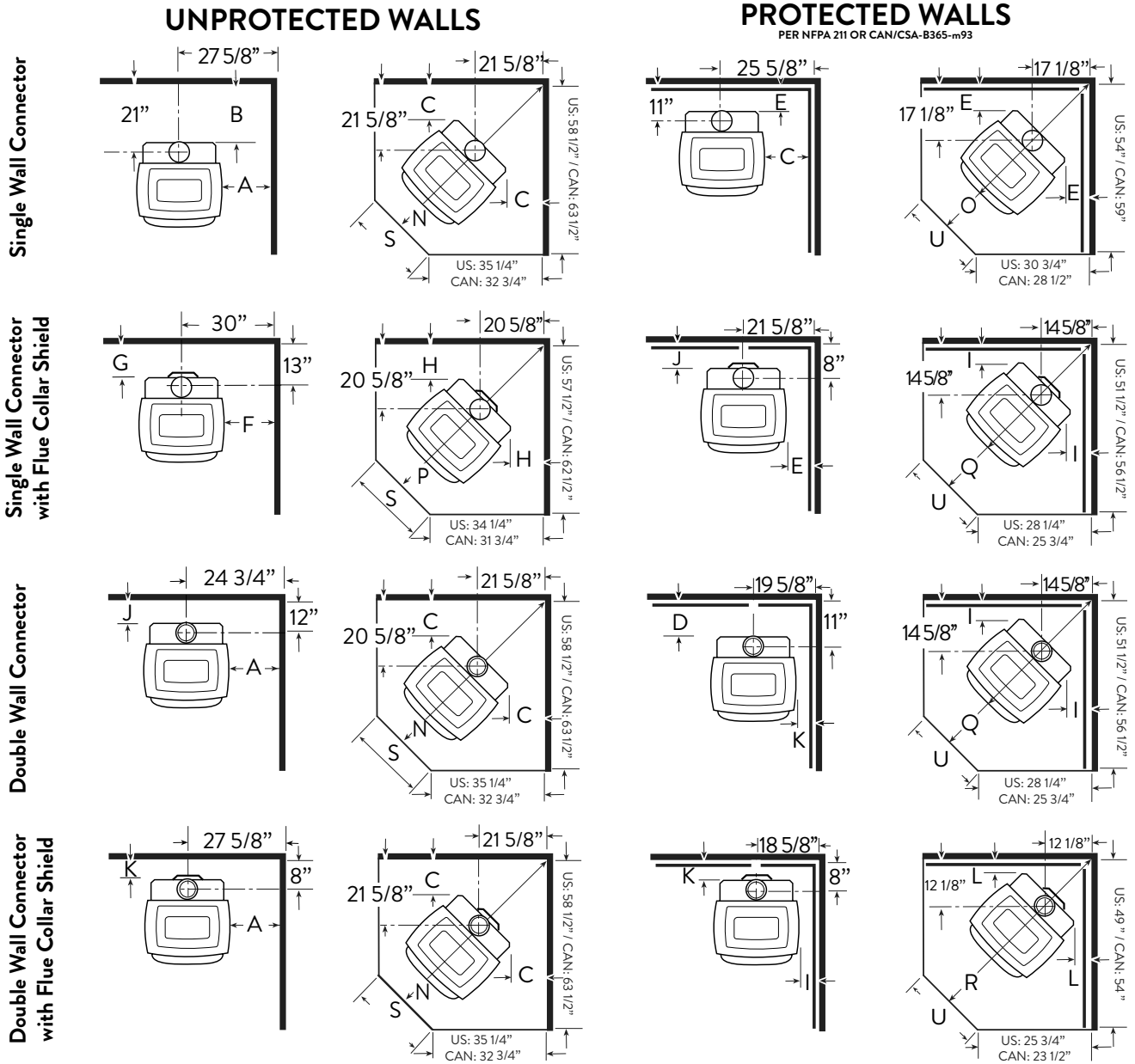

5.0 Operation

Please read the following section before building the first fire in your new Jøtul F 55 V2.

5.1 Combustion Efficiency

The Jøtul F 55 V2 has an EPA tested High Heating Value (HHV) efficiency rate of 67.97%. There are, however, aspects of efficiency that you should be aware of in order to get the most from your stove.

Operation habits and fuel moisture can have a significant effect on efficiency. Poorly seasoned wood having a higher than optimum moisture content, can reduce the amount of energy transferred to the living area as a result of the energy expended to evaporate the excess fuel moisture in order for the wood to burn. Operational aspects, such as not building a robust kindling fire to readily ignite the larger fuel pieces, can result in an inefficient smoldering fire. Additionally, most modern wood heaters' optimum performance and efficiency are at the medium to medium-low burn rates.

The location of the stove can have a significant effect on heating efficiency, primarily in regard to distribution of heat. For example, a wood heater centrally located in the residence in an open living area will likely provide better circulation of heat than will a stove located in a room adjacent to the larger living area.

5.2 Minimize Carbon Monoxide Emissions

Testing the F 55 V2 to CSA B414.1-10 measured carbon monoxide emissions at 1.06 g/min. Most means of combustion produce CO, including wood fires. Maintaining a well-established fire and avoiding operation that produces a smoldering, smoky fire, will greatly reduce CO levels.

It is highly recommended that a CO monitor (detector) be installed in the same room as the stove. The monitor, however, should be located as far away as possible from the stove to avoid alert soundings when adding fuel to the fire.

5.3 Wood Fuel and Performance

The F 55 V2 is designed to burn natural wood only. Higher efficiencies and lower emissions generally result when burning air-dried, seasoned hardwoods, as opposed to softwoods, green or freshly cut hardwoods. Wood that has been air-dried for a period of 6 to 14 months will provide the cleanest, most efficient heat. Wood seasoned more than 2 years will burn too quickly to take advantage of the stove's low end efficiency strength.

A seasoned log will have check marks on the ends and be lighter than an unseasoned log which will show little or no check marks.

We recommend using a moisture meter to determine the moisture content of your wood. For purposes of home heating, your fuel should have a moisture content between 12 - 20%. Wood with higher moisture content will burn, however, very inefficiently. Most of its heat value will be lost to driving water out of the wood. Worse, that moisture will condense as creosote in the relatively cool chimney flue, increasing the potential for a chimney fire. *Use of unseasoned wood defeats the purpose of any modern wood-burning stove.*

BURN UNTREATED WOOD ONLY. DO NOT BURN:

- Coal;
 - Garbage;
 - Synthetic fuel or logs;
 - Material containing rubber, including tires;
 - Material containing plastics;
 - Waste petroleum products, asphalt products, paints, paint thinners or solvents;
 - Materials containing asbestos;
 - Construction or demolition debris;
 - Railroad ties or pressure-treated wood;
 - Manure or animal remains;
 - Lawn clippings or yard waste;
 - Salt water driftwood or other previously salt-water saturated materials;
 - Unseasoned wood;
 - Colored paper, or
 - Paper products, cardboard, plywood, or particle board. *(The prohibition against burning these materials does not prohibit the use of fire starters made from paper, cardboard, saw dust, wax or similar substances for the purpose of starting a fire.)*
 - Burning of any of the materials listed above can result in the release of toxic fumes, cause smoke, or render the heater ineffective and cause smoke
- NEVER USE GASOLINE, GASOLINE-TYPE LANTERN FUEL, KEROSENE, CHARCOAL LIGHTER FLUID OR SIMILAR LIQUIDS TO START OR "FRESHEN-UP" THE FIRE. ALWAYS KEEP SUCH LIQUIDS AWAY FROM THE HEATER AT ALL TIMES.**
- NOTE:** Avoid letting logs rest directly on the glass panel. The logs should be spaced off of the glass enough to allow for proper air flow within the firebox.

WARNING

ALWAYS WEAR STOVE GLOVES WHILE TENDING THE FIRE.

NEVER ALLOW THE FIRE TO REST DIRECTLY ON THE GLASS. KEEP THE LOGS SPACED AT LEAST ONE INCH FROM THE GLASS TO ALLOW FOR PROPER AIR FLOW WITHIN THE STOVE. AVOID STRIKING THE GLASS WITH LOGS.

OPERATE THIS STOVE ONLY WITH THE FRONT DOOR FULLY CLOSED. OPERATION WITH THE DOOR PARTIALLY OPEN MAY RESULT IN OVER-FIRING. IF THE DOOR IS LEFT PARTIALLY OPEN, GAS AND FLAME MAY BE DRAWN OUT OF THE STOVE CREATING SAFETY RISKS FROM BOTH FIRE AND SMOKE.

5.4 How your Jøtul F 55 V2 works

When used with dry wood and a well-drafting chimney system, modern non-catalytic wood stoves burn fuel efficiently by the precise control and delivery of primary and secondary air to the fire.

Primary Air is drawn into a front inlet in the stove bottom and directed through a regulator shutter under the front door before entering the lower fire chamber. Additional primary air is directed to the top of the load door to act as an air wash to help prevent extreme soot build-up on the glass panel. The amount of primary air available to the fire determines the intensity of heat output and rate of fuel combustion; the greater the amount of air, the greater the heat output, the faster the wood burns. The primary air setting also determines air wash effectivity over the glass; the higher the setting, the cleaner the glass.

Additional air is separately directed into the top of the fire chamber to support combustion of exhaust gas before passing out into the chimney. This unregulated *Secondary Air* enters through the stove bottom and is heated as it passes through the rear of the stove into a double-tiered manifold at the top of the firechamber. Additional secondary air is directed through a stainless steel baffle plate.

Volatile gases, released unburned from the fuel bed, rise to the baffle where they are turbulently mixed with hot, fresh oxygen. Secondary combustion then occurs before the gases pass into the heat exchange chamber. See fig. 15.

5.5 Controlling the Fire

Combustion intensity is controlled by the position of an air shutter located under the front door. You adjust its position using the handle located under the ash lip. Slide the handle to the left to decrease air to the fire. Sliding it to the right increases air delivery and fire intensity. See fig. 16. The shutter regulates and directs primary air to the front of the burn chamber. Push it to the right to allow maximum air to support combustion. It should be fully open when first starting or rekindling a fire, or when greater heat output is desired.

5.6 Air Control / Blower Settings

Use the following guide for best performance.

Burn Rate	Air Control Setting	Blower Speed
Low	Min. Open	Low / On at 30 min.
Med.	3/8" Open	Low / On at 30 min.
High	Max. Open	High / On

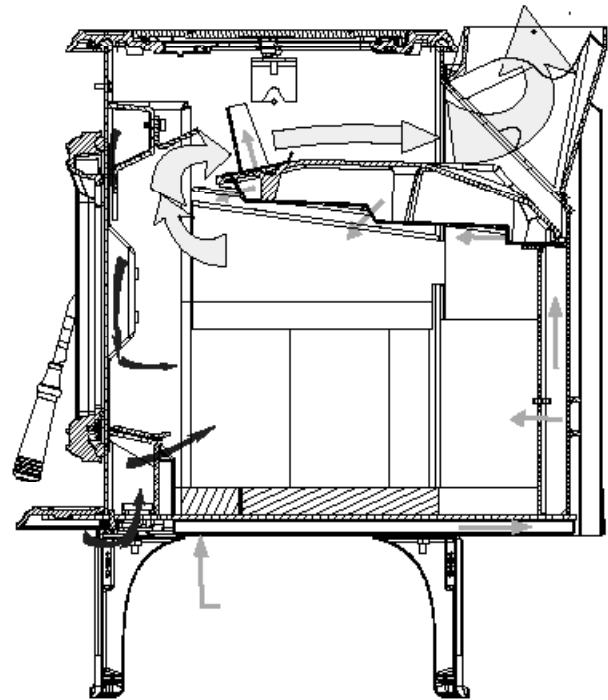
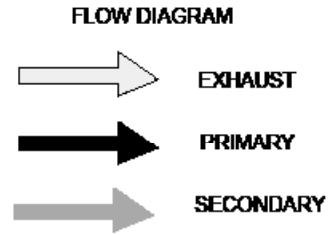

Figure 15. Combustion air paths

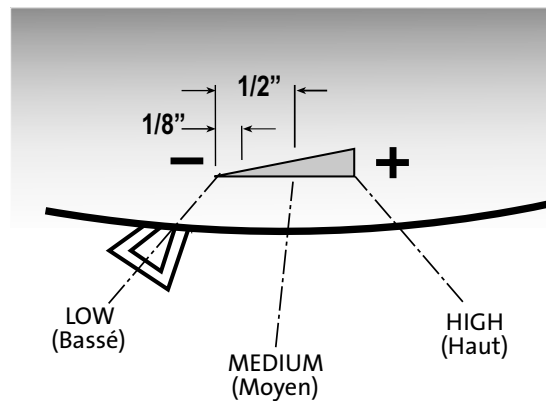

Figure 16. Air Control Settings

5.7 Break-In Procedure

Although your Jøtul F 55 V2 is constructed of welded, 3/16" steel plate, it also incorporates cast iron components. This material requires the stove to be "broken-in" gradually so that heat expansion does not occur too quickly and cause damage. The following steps describe the proper break-in procedure for your stove. Use a magnetic stove-top thermometer to monitor stove temperature, placed directly on the cookplate.

Set the Primary Air Shutter fully open, all the way to the right.

1. Light a small fire of newspaper and kindling at the front of the stove. Gradually add small pieces of wood, but only allow the stove to reach a maximum surface temperature of 200°F (93° C). Continue burning at this low rate for approximately 1 hour.
2. Allow the stove to cool to room temperature.
3. Light a second fire, allowing the stove to reach a maximum temperature of 300°F (149°C) for 1 hour.
4. Cool the stove to room temperature.
5. Light a third fire and gradually allow the stove to reach a surface temperature of 400°F (204°C)
6. Cool the stove to room temperature. This completes the "break-in" procedure.

Note: If the temperature exceeds the limit during any break-in fire, move the Air Shutter all the way to the left to shut off the air supply completely. It is normal that the stovetop temperature will continue to climb until the fuel burns down somewhat. Once the fire is out and the stove has cooled to room temperature, continue the break-in procedure. Never attempt to reduce the temperature by removing burning logs from the fire.

Break-in Odors: It is normal for a newly-painted stove to emit odor and smoke during the first few fires, and these may set off smoke alarms. This condition is caused by curing of the high temperature paint and will diminish with each subsequent fire. It is advisable to open windows or doors to provide plenty of fresh air and cross-ventilation during the break-in period.

WARNING:

NEVER OVER-FIRE THE STOVE. IF ANY PART OF THE STOVE OR CHIMNEY GLOWS, YOU ARE OVER-FIRING. A HOUSE FIRE OR SERIOUS DAMAGE TO THE STOVE OR CHIMNEY COULD RESULT. IF THIS CONDITION OCCURS, IMMEDIATELY CLOSE THE AIR CONTROL.

ATTEMPTS TO ACHIEVE HEAT OUTPUT RATES THAT EXCEED HEATER DESIGN SPECIFICATIONS CAN RESULT IN PERMANENT DAMAGE TO THE HEATER.

5.8 Starting and Maintaining a Fire

Burn only solid wood directly on the bottom of the stove firechamber. Do not elevate the fire in any way.

We recommend use of a magnetic stovetop thermometer to monitor the surface temperature of the stove. Locate the thermometer directly on one of the corners of the top plate. The optimum surface temperature range for most efficient combustion is between 400° and 700° (204°C -371°C). Chimney draft should be in the .05 - 1.0 w.c. range.

Section 7.7 of the Appendix shows the cordwood test method fire building procedure for a high fire with a cold start.

Traditional Fire Building

1. Set the air control lever in the full open position (*to the right*), place several sheets of crumpled paper directly on the grate. On top of the newspaper, place a dozen or more pieces of small dry kindling (approx. 1" in square) with two to three larger logs (approx. 3" to 5" in square) on top.
2. Light the fire and close the door, slowly building the fire by adding larger and larger logs. Be sure to follow the break-in procedure before creating a hot fire that might damage the stove.
3. Once the stove has reached a surface temperature range of between 400° and 600°, (204°C -316°C), adjust the primary air control lever as necessary to generate the heat output and burn time desired.

Top-Down Fire Building

Many people find this method to be superior to the traditional method. It quickly establishes a clean-burning fire.

1. Set the air control lever in the full open position (*to the right*), and place two short 1/4-split logs on the firebox floor, perpendicular to the rear wall, about 6 inches apart.
2. Place three or four smaller splits across the base logs.
3. Place several thin kindling sticks on top of the small logs.
4. Place newspaper and wood scraps on top of the kindling, light the paper and close the door. The burning paper will help heat the flue to establish draft while the kindling ignites and falls onto the fuel below. Keep the air control fully open until the fire is well-established.
5. Add more logs as the fuel bed become fully involved and use the stove-top thermometer to monitor progress. When the stove has reached a surface temperature range of between 400° and 600°, (204°C -316°C), adjust the primary air control lever as necessary to generate the heat output and burn time desired.

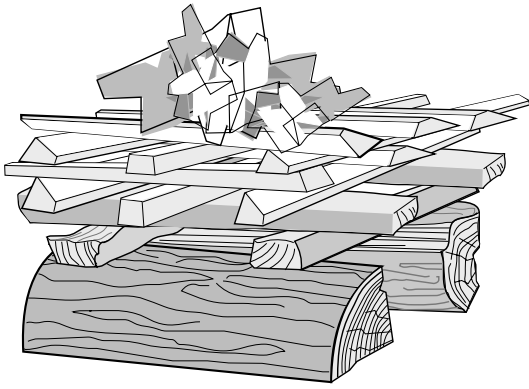

Figure 17. Top-down fire starting structure.

You can also monitor stove performance through the window. Peak combustion efficiency occurs when exhaust gas is burned at the baffle in the top of the firebox. This is apparent as rolling yellow-orange flames appearing at the secondary air ports in the underside of the baffle plate and forward tube. At this stage, little or no smoke will be visible exiting the chimney.

5.9 Adding Fuel

Follow this procedure when reloading the stove while it is still hot and a bed of hot embers remains:

- Always wear gloves when tending to the stove.
- Adjust the Primary Air Shutter Lever to the fully open position. Wait a few seconds to re-establish strong draft before opening the load door. This will allow fresh air to flush the firebox and prevent smoke escaping when the door is opened.
- Minimize CO exposure: Open the door slightly, and hesitate a moment to allow exhaust purge, then open the door fully.
- Use a stove tool or poker to evenly distribute coals and embers around the firebox.
- Load the fuel, usually with smaller logs first.
- Close the door, being sure to latch the door tightly.
- Wait 5 – 10 minutes to re-establish the fire before setting the air controls for the desired heat output and burn time. (If there is at least a 2" thick ember bed when reloading, it may be possible to close the door and immediately adjust the air control setting).
- Set the Air Shutter for the desired heat output.

WARNING: Operate the stove only with the front door fully closed except for refueling. Operation with the door partially open may result in overfiring. Also, if the door is left partially open, combustion gas and flame may be drawn out of the stove, creating risks from both fire and smoke.

5.10 Creosote Formation and the Need for Removal

When wood is burned slowly, it produces tar and other vapors that combine with moisture to form creosote. Creosote vapors condense in the relatively cool chimney flue, and creosote residue accumulates on the flue lining. When ignited, this creosote fuels an extremely hot fire.

The chimney connector and chimney flue should be inspected at least every other month during the heating season to determine if creosote buildup has occurred. If creosote has accumulated, it should be removed to reduce the chance of a chimney fire.

In the event that creosote ignites in the flue, the resulting fire is often accompanied by a roaring noise and crackling sound as flakes of burning creosote break loose. If you suspect you are having a chimney fire, immediately close the air controls and make sure the door is closed securely. Call the fire department and have everyone leave the house.

Do not attempt to extinguish the fire. Opening the door will only supply additional oxygen and intensify the fire. When the fire in the flue has subsided, resist the temptation to open the door to check on the fire. The fire may have suffocated, but could re-ignite with a supply of fresh air. After a chimney fire, do not use the stove until the chimney connector and flue have been cleaned and inspected to ensure no damage has been sustained. See Section 6.6 of this manual regarding chimney cleaning.

5.11 Ash Removal

Remove ashes whenever accumulation nears the primary air port located inside the firechamber just under the door opening. Keep a 1 inch layer of ashes in the stove to help maintain a hot coal bed.

Always wear safety gloves when handling the ashes.

Ashes should only be placed in a metal container equipped with a tight sealing lid. The container should be placed on a noncombustible floor or on the ground, well away from all combustible materials, pending final disposal. If the ashes are to be disposed of by burial in soil or otherwise locally dispersed, they should be kept in the closed container until all cinders have thoroughly cooled.

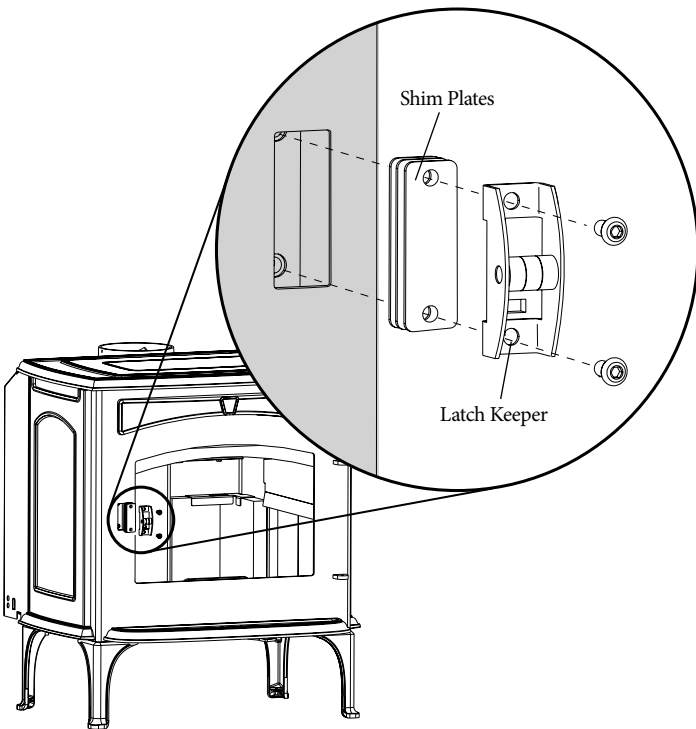

Figure 17. Latch adjustment.

6.0 Maintenance

6.1 Door Latch Adjustment

Over time, as the door gasket becomes compressed, it may be necessary to adjust the door latch in order to maintain the integrity of the door seal. To check the seal of the front door, close and latch the door on a dollar bill and slowly try to pull the bill free. You should feel resistance as you pull. If it can be easily removed, the seal is too loose. Follow this procedure to tighten the latch mechanism.

Tools Required: 4 mm hex key

1. Remove the two socket head screws and latch keeper from the stove. See fig. 17.
2. Remove one of the shim plates from the latch cavity and re-install the latch keeper. Retain the shim plate(s) removed for future use.
3. Test the seal integrity using the dollar bill.

The door gasket will compress over time. When the latch can no longer be tightened by shim removal, install a new gasket and replace the shim plates.

6.2 Glass Care

Cleaning

On occasion, it will be necessary to clean the carbon deposits and fly ash off of the glass. If these deposits are allowed to remain on the glass for an extended period of time, the surface may become etched and cloudy. Any creosote that might develop on the glass will burn off during the next hot fire.

Follow this glass cleaning procedure:

1. Glass must be completely cool.
2. Only use a cleaner that is specifically designed for this purpose. The use of abrasives will damage the glass and ultimately leave the glass frosted. **DO NOT USE AMMONIA-BASED GLASS CLEANERS.**
3. Rinse and dry glass completely before burning the stove. Polish with a piece of newspaper.

Caution! Open and close the door slowly and carefully to avoid cracking or breaking the glass. Never use the door to push wood into the firebox. If the glass becomes cracked or broken follow the replacement procedure below.

Do not operate the stove with a cracked or broken glass panel.

Important: Replace glass only with ceramic glass panel PN 224158 specifically designed for the Jøtul F 55. Do not use substitutes. Replacement glass is available from your local Jøtul dealer.

6.3 General Care

Regular maintenance will assure good performance and prolong the life of your stove. The following procedures do not take long and are generally inexpensive. When done consistently, they will increase the life of your stove and in turn provide years of enjoyment.

- Regularly empty the stove of all soot and ashes. Only use a vacuum for this job if the vacuum is specifically designed to handle ashes. **CAUTION:** Ashes can contain live embers. Be certain the ash bed contains no live embers before using a vacuum.
- Inspect the stove: Using a strong light inspect the stove inside and out for cracks or leaks.
- Replace any broken bricks. See fig. 28, page 26. **DO NOT OPERATE THE STOVE WITH BROKEN OR MISSING BRICKS.**

6.4 Gasket Replacement

1. Use pliers and a putty knife to remove the old gasket and adhesive from the door.
2. Thoroughly clean the channel with a wire brush.
3. Apply a small bead of cement to the channel.
4. Gently press the new gasket into the cement to seat it in the channel. Wrap the two ends around and join the ends at the center of the bottom as in fig. 18. Close and latch the door and then reopen. Wipe away any excess cement that may have squeezed out from around the gasket.

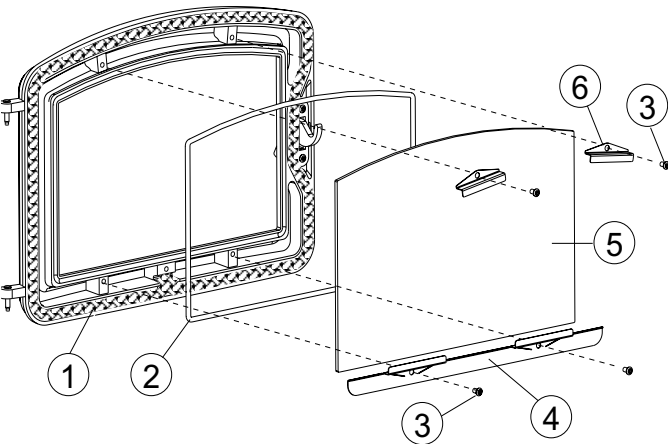

Description	Part Number
1. Door Gasket (6 ft.)	223858
2. Glass Gasket (4 1/2 ft.)	129644
3. Screw, M6x10 Button Hd.	117978
4. Lower Glass Clip Ass'y.	157641
5. Glass Panel	224158
6. Upper Glass Clip Ass'y.	157352

Figure 18. Glass and Gasket Replacement

6.5 Glass Removal or Replacement

See fig. 18

1. Place the door face down on a protected surface.
2. First just loosen each M6 x 10 mm button head glass clip screw and then remove the clips.
3. Lift the glass panel out of the door. Use pliers and a putty knife to remove the old glass gasket. Replace with PN 200024, .025 dia. LD2 gasket. Apply a small bead of cement in the channel and gently press the gasket into place.
4. Replace the glass and glass clips. Tighten the clips gradually, avoiding placing uneven pressure on the glass.

6.6 Chimney System

The Jøtul F 55 V2 is designed to burn cleanly and efficiently when used according to the guidelines in this manual. In order to maintain proper performance, you should inspect the chimney and chimney connector at the beginning of each heating season and then every other month during the heating season. Clean the chimney whenever creosote and fly ash accumulation exceeds 1/4 inch in any part of the system.

Chimney brushes are available from your local Jøtul dealer or hardware supply store. Your dealer can also refer you to a reputable, professional chimney sweep who will have all the equipment to ensure a complete and proper job.

WARNING: FAILURE TO KEEP THE CHIMNEY CONNECTOR AND FLUE FREE OF CREOSOTE BUILD-UP CAN RESULT IN A CHIMNEY FIRE.

6.7 Replace Firebricks

DO NOT OPERATE THE STOVE WITH BROKEN OR MISSING BRICKS.

See fig. 28, page 26 and the parts listing on page 27 for the configuration and part number of any firebricks that require replacement. Order through your local Jøtul Authorized Dealer.

7.0 Appendix

7.1 Optional Blower 156431

Tools Required

- 10 mm wrench or socket driver
- pliers
- 1/4" socket driver or flat head screwdriver
- 4 mm hex key
- work gloves

CAUTION:

Avoid injury- always wear work gloves when handling sheet metal parts. Read through these instructions to familiarize yourself with these parts before beginning the installation.

- 115 VAC, 60 HZ, Max. 40 Watts
- This blower must be electrically grounded in accordance with local codes or, in the absence of local codes, with the current ANSI/NFPA 70, National Electrical Code or CSA C22.1-Canadian Electrical Code.
- This unit is supplied with a three-prong (grounding) plug for protection against shock hazard and should be plugged directly into a properly grounded three-prong receptacle. **DO NOT CUT OR REMOVE THE GROUNDING PRONG FROM THE PLUG.**
- Do not connect to power supply until all electrical connections have been made.
- Always disconnect the power supply when performing any service.

Installation

Install the blower kit before moving the stove into its final position. If the stove is already installed, you may need to pull it out to install this blower.

For Freestanding stove installations, where access to the back of the stove is unrestricted, the Control Box may be mounted to either corner of the rear shroud.

For Alcove or Hearthmount installations into fireplaces, the Switch Box must be mounted under the stove, attached to the stove using the left front leg stud. Determine the location most appropriate to your needs and follow the installation steps outlined below.

1. Remove the Rear Shroud:

Use the 10 mm wrench or socket driver to remove the hex head bolts at the bottom of each side of the Rear Shroud. See fig. 21, (A).

Loosen the two hex nuts at the upper rear of the stove and lift the shroud up off of the stove. See fig. 21, (B). Keep all shroud fasteners for reassembly.

2. Attach the Air Deflector: See figs. 19 and 21 /#3.

Use pliers to bend the deflector tabs at the perforation lines as shown. Attach the deflector to the interior side of the rear shroud using two #8 X 12 sheet metal screws from the exterior side.

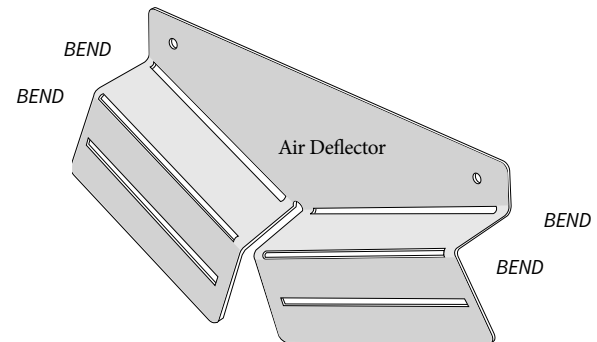

Figure 19. Air Deflector orientation.

3. Attach the Blower Mounting Bracket.

Use pliers to bend back the long, vertical flange to allow the bracket to fit flush against the back of the stove. (Fig. 19 and 21 /#2) to the two center studs on the back of the stove, oriented as shown. Secure with two M6 flange nuts.

4. Attach the Blower to the Mounting Bracket using the two wing nuts (Fig. 21 /#9).

5. Attach the Snapstat Bracket to the lower stud on the back of the stove, oriented as shown in fig. 21 /#7.

Slide the small Snapstat (#6, marked F110-20) all the way into the bracket slot between the stove and the bracket. Connect either snapstat lead to either snapstat terminal.

6. Install the Control Box, fig. 21 /#4:

The Control Box may be mounted to the side of the stove closest to the nearest electrical outlet.

Freestanding Installation-

Attach the control box to either side of the rear shroud using a 1/4" socket driver and one #8 x 12 sheet metal screw as shown in fig. 21.

Alcove or Hearthmount Installation -

Attach the Control Box Mounting Bracket (#5) to the back of the Control Box (#4) using two #8 x 12 sheet metal screws.

Install the M8 hex nut on the left front leg stud and engage the slotted Mounting Bracket/Control Box assembly between that nut and the leg nut. See fig. 21.

Figure 20. Blower Bracket adjustments.

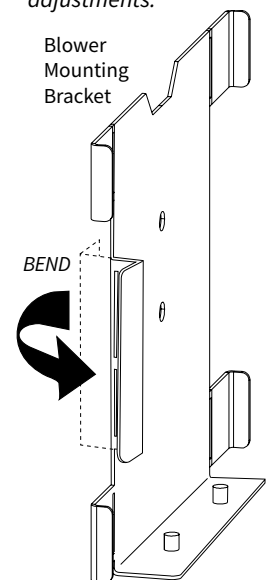
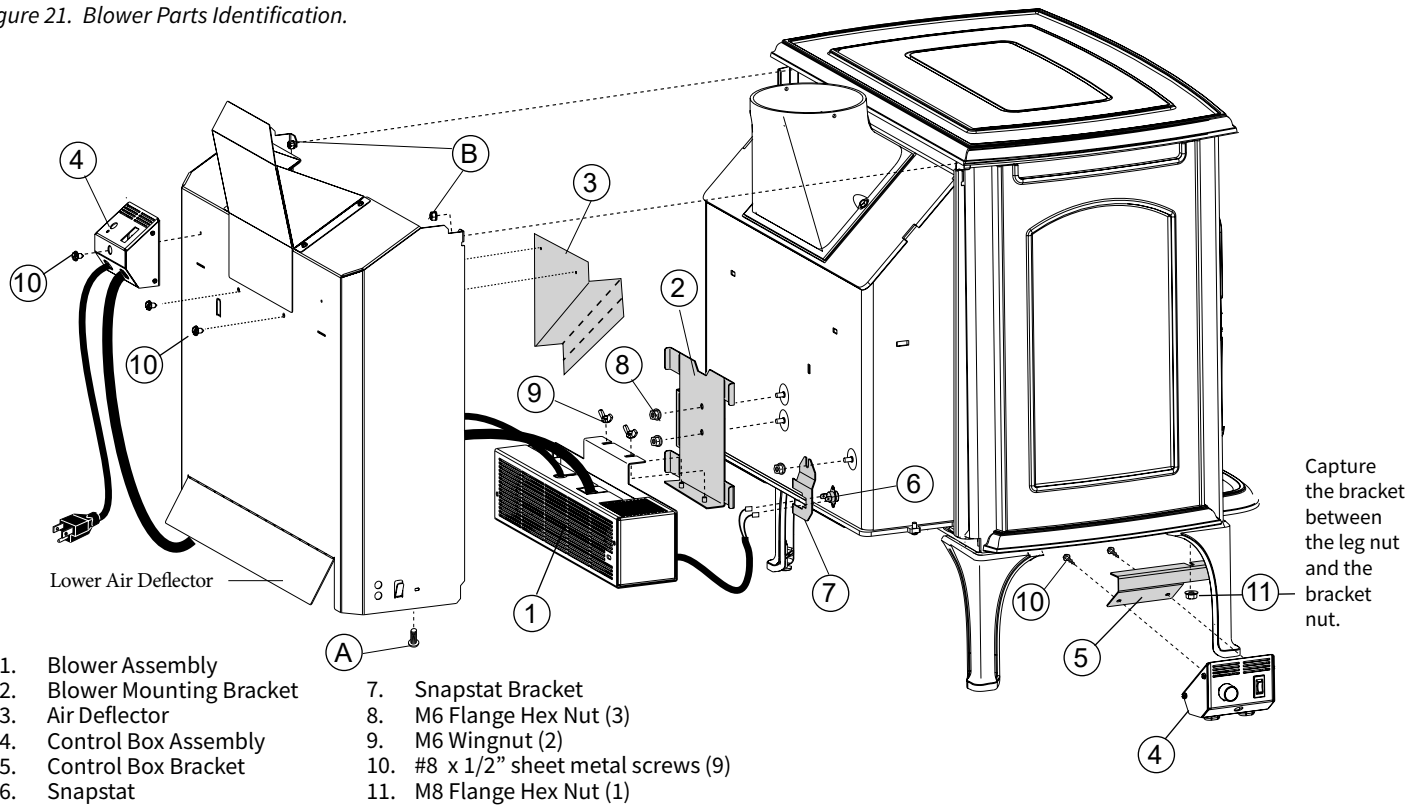

Figure 21. Blower Parts Identification.



7. Bend back the Lower Air Deflector panel on the rear shroud.

Reinstall the shroud by reversing the procedure in Step 1. Engage the shroud with the upper hex nuts on the back of the stove and then reinstall the hex head bolts at the bottom of each side.

8. Route the power cord to the nearest electrical outlet.

Operation

The blower is controlled by the heat-activated snapstat that will only function when the control switch is set in AUTO. After the fire is established, the snapstat will react to the heat and activate the blower. Fan speed may be manually adjusted with the rheostat knob. The blower will shut off automatically as the stove cools down. If automatic blower circulation is not desired, place the blower control switch in the MANUAL position.

Maintenance

Disconnect the blower from its power source before cleaning or servicing.

Regular cleaning will help ensure you obtain maximum life from the blower. Use a vacuum with a soft brush attachment to clean the blower fans and motor housing at least monthly, or more frequently if there are pets in the home. Keep the area under the stove free of dust and debris.

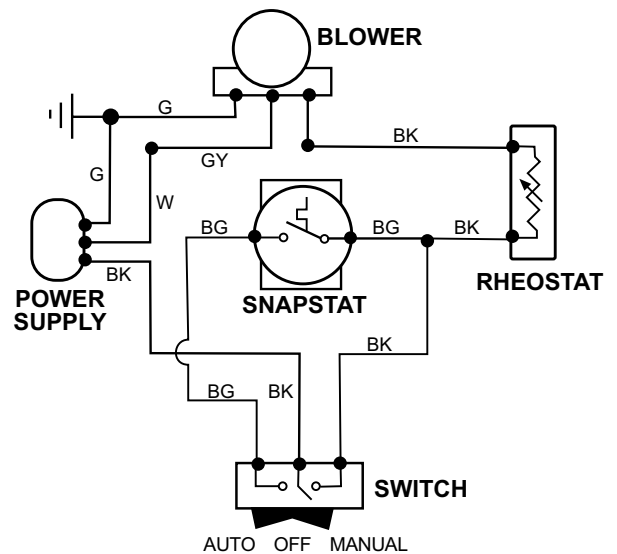

Figure 22. Blower Wiring diagram.

7.2 Outside Air Kit #158208

NOTE: This kit cannot be used with the Short Leg Kit.

Contents:

- Outside Air Manifold (fig. 23)

Tools Required:

- 10 mm socket driver or wrench
- safety glasses
- work gloves

You will need to acquire the following additional components available at any hardware supplier:

- Exterior Air Inlet Cover
- 4" Aluminum Duct
- Rodent Screen
- 4" Duct Clamps, 2

The exterior air inlet should not be installed at a level higher than the stove bottom.

1. Use the 10 mm socket driver or wrench to remove the four nuts that secure the steel secondary air manifold to the stove bottom and remove the manifold (Fig. 28, #32).
2. Replace the secondary manifold with the Outside Air Manifold and secure it to the stove bottom using the original M6 nuts.
3. Connect the outside air duct, (not provided) to the collar using a duct clamp. Secure the other end of the duct to the interior collar of the Air Inlet using the remaining clamp.

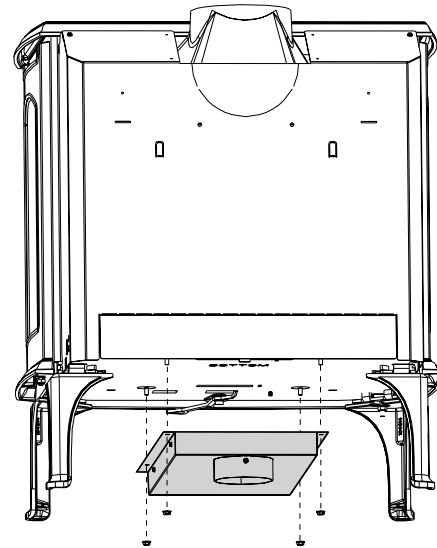

Figure 23. Outside Air Adaptor installation.

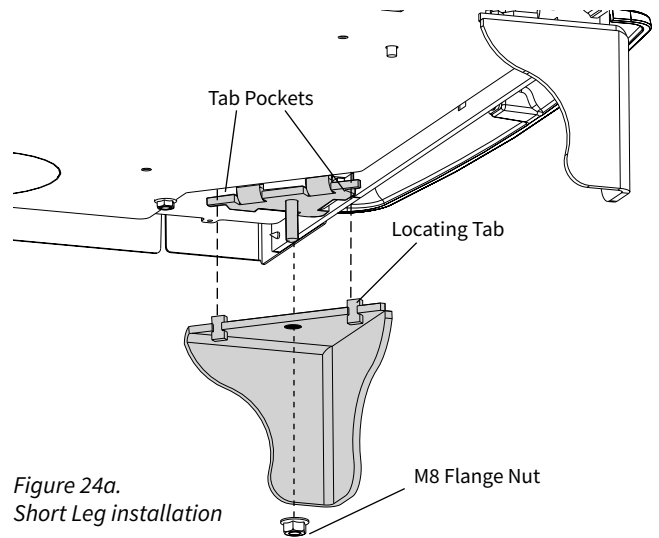

Figure 24a.
Short Leg installation

7.3 Short Leg Kit #158209

Approved for use only in fireplace hearth mount code-approved installations.

Contents:

- 4 1/4" Steel Legs (4)
- M8 Flange Nuts (4)
- Bottom Heat Shield

Tools Required:

- 13 mm Wrench or Socket/Ratchet
- Work Gloves
- Safety Glasses
- Assistant

DO NOT LIFT THE STOVE UP BY THE ASH LIP.

1. Have an assistant tilt the stove up on one side enough to remove the cast iron legs. Fully remove the nuts from the leg studs.
2. Engage the steel leg with the mounting stud. Be certain the two locating tabs on each leg seat with the corner pockets in the stove bottom. Tighten the nuts using the 13 mm wrench and carefully set the stove back down. See fig. 24a.
3. Repeat the leg installation on the opposite side.
4. With the stove on the ground, place the Bottom Heat Shield over the leg studs. Use the M8 flange nuts in the kit to secure the shield to the leg studs. See figure 24b.

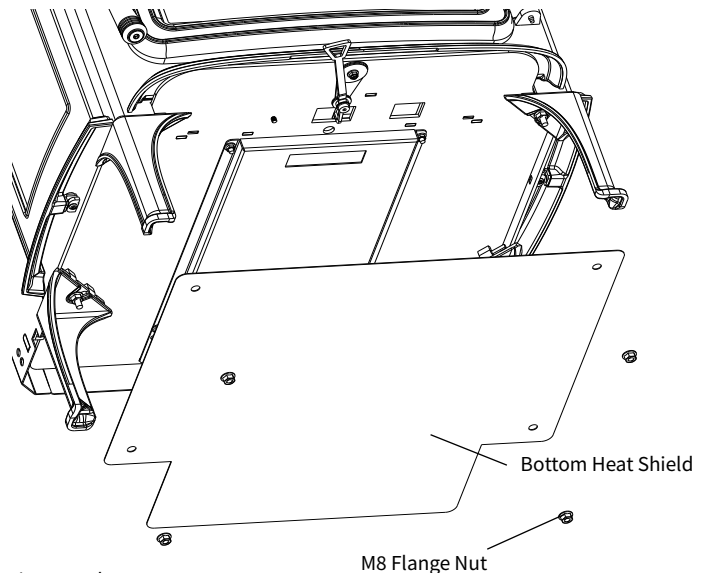

Figure 24b.
Bottom Heat Shield installation

7.4 Mobile Home Floor Bracket Kit 157321

Contents: Floor Brackets, 2

Fasteners Required: 3/8" dia. lag screws, 2

1. Determine the final location of the stove and use the leveling bolts to plumb and level the stove.
2. Mount the floor brackets over levelling screws at rear and front locations at opposite corners and secure each to the floor using a 3/8" dia. length lag screw of appropriate length (not supplied).

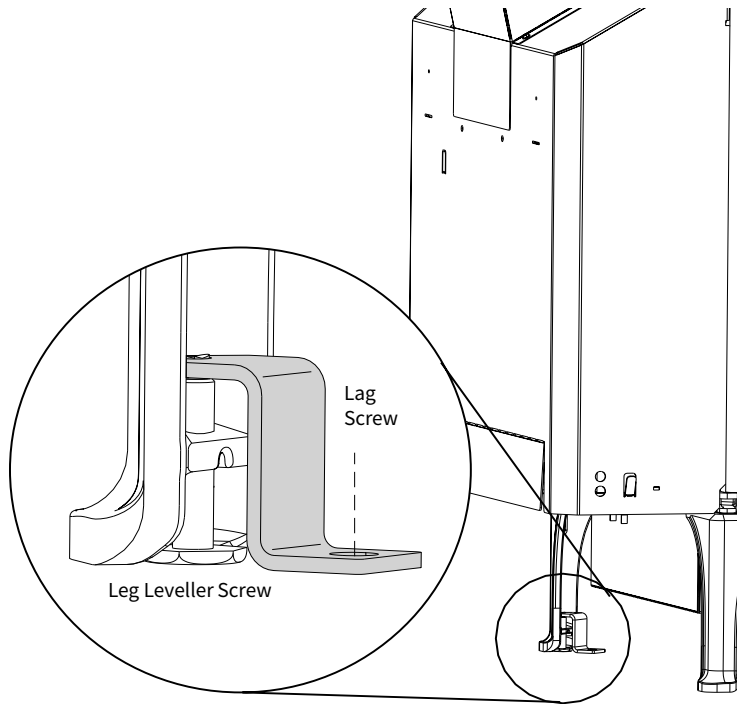

Figure 25. Floor Bracket Detail

7.5 Alternate Floor Protection

All floor protection materials must be non-combustible ie. Metal, brick, stone, mineral fiber boards). Any combustible material may not be used.

The easiest means of determining if a proposed alternate floor material meets requirements listed in this manual is to follow this procedure.

R-value = thermal resistance

K-value = thermal conductivity

C-value = thermal conductance

1. Convert the specification to r-value;
 - a. If r-value is given, no conversion is needed.
 - b. If k-value is given with a required thickness (t) in inches: $R=1/k \times T$.
 - c. If c-value is given: $R=1/C$.
2. Determine the r-value of the proposed alternate floor protector.
 - a. Use the formula in step 1 to convert values not expressed as "R".
 - b. For multiple layers, add r-values of each layer to determine overall r-value.
3. If the overall R-value of the suestem is greater than the R-value of the specified floor protector, the alternate is acceptable.

Example:

The specified floor protector should be 3/4" thick material with a k-factor of 0.84. The proposed alternate is 4" brick with a c-factor of 1.25 over 1/8" mineral board with a k-factor of 0.29.

Step A. Use formula above to convert specifications to R-value. $R=1/k \times t= 1/.84 \times .75 = .893$

Step B. Calculate r of proposed system.

4" brick of c-1.25, therefore

$R \text{ brick} = 1/c = 1/1.25 = 0.80$

1/8" mineral board of K = 0.29 therefore

$R \text{ mineral board} = 1/.29 \times 0.125 = 0.431$

Total R = R brick + R mineral board= 0.8 + 0.431=1.231

Step C. Compare proposed system R = 1.231 to specified R of 0.893. Since R is greater than required, the system is acceptable.

Definitions:

Thermal conductance =

$$C = \frac{\text{btu}}{(\text{Hr})(\text{ft}^2)(\text{f})} = \frac{\text{W}}{(\text{m}^2)(\text{k})}$$

Thermal conductivity =

$$K = \frac{\text{btu}}{(\text{Hr})(\text{ft}^2)(\text{f})} = \frac{\text{W}}{(\text{m}^2)(\text{k})} = \frac{(\text{btu})}{(\text{hr})(\text{ft})(\text{f})}$$

Thermal resistance =

$$R = \frac{\text{btu}}{(\text{Hr})(\text{ft}^2)(\text{f})} = \frac{(\text{m}^2)(\text{k})}{\text{W}} = \frac{(\text{btu})(\text{inch})}{\text{W}(\text{hr})(\text{ft}^2)(\text{f})}$$

7.6 Secondary Air Manifold Maintenance

Tools Required:

- 10 mm 9 lbs. ft. torque gun or open-end or socket wrench
- 13 mm 16 lbs. ft torque gun open-end or socket wrench
- Small 3mm allen head tool
- Drill with 1/4" hex socket bit
- Soft brush or shop vaccum
- Work Gloves
- Safety Glasses
- Assistant

During inspection as instructed in section 6.3 General Care, the secondary air manifold may need to be replaced due to warping, cracking or any functional defect. Call your authorized Jøtul dealer for service.

Follow these instructions for cleaning or replacement of the the secondary air manifold:

1. Disconnect chimney connector from smoke outlet and move the stove away from walls for ease of access to the rear. Use an assistant to move the stove and reduce potential injury.
- 2.. Use a 10 mm open-end or socket wrench to remove the two flange nuts on studs that hold the rear shroud onto the stove.
3. Use a small 3mm allen head tool to remove the two allen heads on the bottom brackets.
4. Use a 10mm open-end or socket wrench to remove the (1) M6x20 bolt from the secondary air manifold on rear of stove.
5. With one hand on the inside of the smoke outlet holding the M6 flange nut, use a 10mm open-end or socket wrench to remove the (2) M6x20 bolts from smoke outlet. Place the smoke outlet out of the way.
6. Use a 13 mm open-end or socket wrench to remove the (2) M8 flange nuts with M8 fender washers retaining the top plate assembly. Access through smoke outlet opening is adequate.
7. Wearing gloves and using both hands or assistance from another person, lift the top plate assembly off of stove. Locate the plate out of the way on a protected surface.
- 8.. Using both hands and avoiding skin contact, lift the insulation blanket up and off top of baffle and out the top opening. Place it on a flat surface taking care to retain its shape. Inspect the blanket for damage and replace it if necessary.
9. Lift the exhaust deflector up and off the two shoulder bolts inside the front plate.
10. Using both hands, remove the secondary air manifold with turbulator through the top opening.
11. Use a soft brush or shop vaccum to remove any fly ash or other loose debris from turbulator and secondary air manifold. Inspect and confirm that the turbulator is secure to the manifold top.

12. Inspect and replace damaged gaskets at the smoke outlet and secondary air manifold.
13. Resecure the secondary air manifold with turbulator to the stove. Use the 10mm open-end or socket wrench to install the (1) M6x20 bolt into rear of stove.
14. Looking through the front door, verify the lip of the manifold is inside firebox air channel and that the manifold is contacting the gasket evenly. Ensure that the gasket is not hanging down. The manifold should rest evenly on both side supports. Readjust manifold if necessary.
15. Using both hands and avoiding skin contact, reinstall the insulation blanket. Fold the blanket over the sides of the air manifold and position the front edge of the blanket even with front edge of the baffle ensuring the turbulator is not obstructed.
16. Using both hands, or assistance from another person, position the set screws on the top plate through the top brackets of firebox.
17. Ensure that the gasket is even around firebox top. Using the 13mm open-end or socket wrench, reinstall the M8 flange nut with M8 fender washer onto each set screw on top plate.
18. Hang the exhaust deflector onto the two shoulder bolts.
19. Reinstall rear shroud to stove. Hang serial plate onto the rear shroud.
20. Prior to reattaching the chimney connector to the smoke outlet, confirm the correct placement of the stove on the floor. See Section **4.6, Clearance to Combustables**.

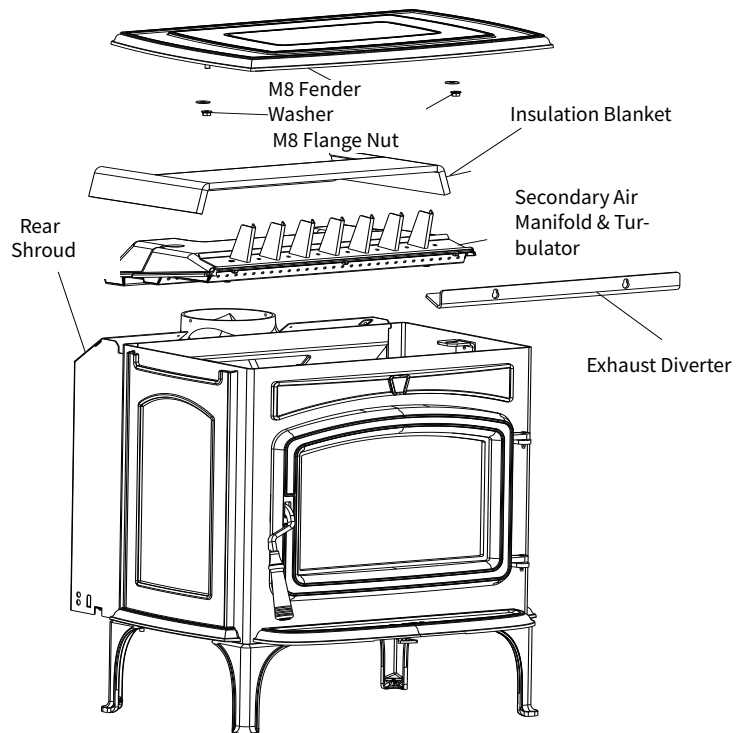

Figure 26. Overview of secondary air manifold removal

7.7 F 55 V2 Start-Up and Refueling

Follow these directions to get the best emissions performance from your F 55 V2:

Cold Start

Use the following technique for the best start from a “cold” stove:

1. Cut and split kindling pieces approximately 16” long. The recommended piece size is 1/2 ” - 3/4” in cross section. The kindling should be very dry and the total weight would be about 4-1/2 lbs. if hardwood. A recommended stacking arrangement of the fuel pieces is shown in Figure 27.
2. The next fuel increment size for the “start up” pieces should be the same length but a bit larger between 1” to 1-1/2” in cross section. The start-up fuel should total about twice as much in weight as the kindling. Again, the criss-cross loading technique will provide ample air flow through the pieces resulting in a robust start-up.
3. When using a “top down” starting method the start-up pieces will be on the bottom of the firebox with the kindling pieces arranged on top of the start-up pieces.
4. Make sure the air control is fully positioned to the right in which the air control will be full open.
5. For quick and easy ignition a propane torch can be used for about 60 seconds. If doing the top down start-up, light the top front of the pile.
6. Close the door until the latch hits. This will leave the door in a slightly open position.
7. After one minute, close the door fully and secure the door latch.
8. Make sure the air control is still in the maximum open position.

Medium Fire

1. At the end of the previous burn cycle, rake and arrange the remaining coals until they are equally distributed and level across the firebox.
2. Load with all pieces in a front to back (north / south) orientation. Load the larger pieces in the center and make sure there is some space on each side for good air flow.
3. Immediately close the load door and set the air control to maximum open (fully to the right).
4. After 5 minutes, set the air control to the medium position which is in the center of the travel range.

Low Fire

1. At the end of the previous burn cycle, rake and arrange the remaining coals until they are equally distributed and level across the firebox.
2. Load with all pieces in a front to back (north / south) orientation. Load the larger pieces in the center and make sure there is some space on each side for good air flow.
3. Immediately close the load door and set the air control to maximum open (fully to the right).
4. After 15 minutes, adjust the air control handle to the center position and leave it there until the fire is well established on the top of the wood below the baffle. Gradually reduce the air setting over a period of up to 15 minutes until the air control is all the way to the left (minimum air position).

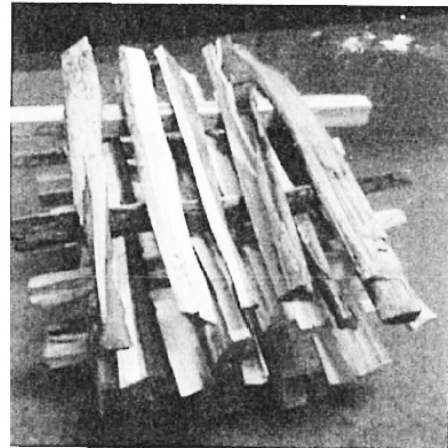

Figure 27. Criss-Cross Kindling Pattern

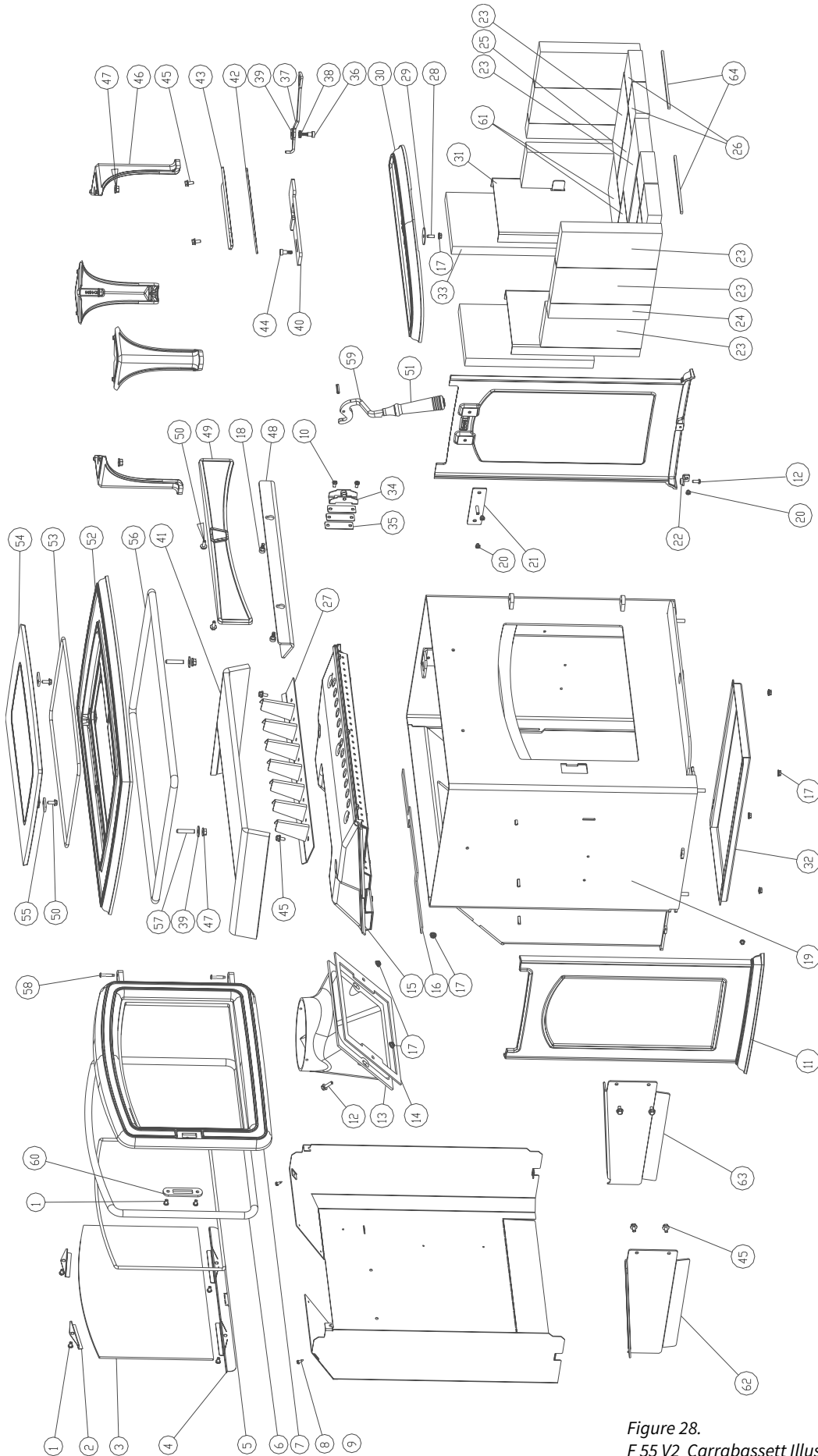

Figure 28.
F 55 V2 Carrabasset Illustrated Parts

8.0 Jøtul F 55 V2 Carrabassett Parts List

No.	Part Number	Description
1	117978	Screw, Button Head Socket M6X10 Blk
2	157352	Glass Clip w/Gasket, Top, Steel Stoves
3	224158	Glass, Ceramic, Door, 50 TL
4	157641	Glass Clip w/Gasket, Bottom F55
5	129644	Gasket, LD 250 Fiberglass Rope
6	223858	Gasket, MD, .625 Ø Fiberglass Rope
7	157351	Door, Front, w/Gasket, Steel Stoves, MB
8	117917	Screw, HWH SMA 8 x 1/2 SL Blk Oxide
9	22673392	Rear Shroud, F 55 V2, MB
11	157354	Convection Panel, Right, MB, D&T
12	117117	Bolt, Hex Serrated Flange M6 x 20 Blk
13	103326	Smoke outlet, MB
14	224350	Gasket, Flue Collar, 50 TL
15	158194	Secondary Air Manifold Assy.
16	224778	Gasket, Rear Secondary Air Manifold
17	117968	Nut, M6 Serrated Flange plain
18	118244	Screw, Shoulder, M6 Thd, 8mmØx6mm
20	118170	Screw, Button Head Socket, M6 X 6, Blk
21	226582	Bracket, Top, Cast Convection Panel, 50 TL
22	224197	Bracket, Bottom, Cast Convection Panel,
23	129082	Brick, Refractory, 4.50" x 9" x 1.25"
24	220390	Brick, Refractory, 9" x 1.88" x 1.25"
25	222226	Brick, Refractory, 9" x 3.375" x 1.25"
26	224175	Brick, Refractory, 4.0" x 3.0" x 1.25"
27	226681	Turbulator assembly, F55 V2
28	118031	Screw, Socket Set M6 x 16
29	118029	Washer, Fender .250 x 1.500 dia.
30	157348	Ashlip, 50 TL, MB, D&T
31	226730	Cover, Vermiculite Panel
32	226680	Manifold, Bottom Secondary Intake
33	226729	Vermiculite Panel
34	224733	Latch Receiver, Front Door

No.	Part Number	Description
35	224734	Shim, Latch Receiver
36	117982	Screw, Shoulder, M6x10 Thd, 8
37	225391	Air Valve Handle Ass'y, Nickel Plated
38	118249	Disc Spring
39	117949	Washer, Fender 8mm Zinc
40	226650	Air Valve, F55 V2
41	226682	Blanket, Ceramic
42	224355	Gasket, Inspection Cover, 50 TL
43	224924	Inspection Cover
44	117982	Screw, Shoulder, M6x10 Thd, Hex Drv
45	117130	Bolt, Hex Head Serr Flange M6x12 Blk
46	157346	Leg, Steel Stoves, MB, D&T
47	117881	Nut, M8, Serrated Flange, DIN 6923
48	224458	Exhaust Deflector, F 55
49	157353	Eyebrow Steel Stoves, MB, D&T
50	99625	Bolt, Hex Head Serr Flange M6x16 Blk
51	157262	Front Door Tool, Nickel Plate
52	157356	Top Plate, TL Stoves, MB, D&T
53	100038	Gasket, .360 LD2
54	104627	Top Cover, F 55
55	128401	Side Clip, (Hang Tab)
57	118245	Set Screw, M8 x 40, Hex Socket, Steel,
58	225098	Hinge pin, slotted, Nickel Plate
59	157457	Latch, Front Door, Black
60	224159	Retainer, Front Door Latch, 50 TL
61	224723	Brick, 6.625 x 4.5 x 1.25
62	226765	Brick Retainer, Left, F 55 V2
63	226766	Brick Retainer, Right, F 55 V2
64	226628	Brick Locator

Only use replacement parts provided through your authorized Jøtul dealer.

9.0 Jøtul F 55 V2 Carrabassett Limited Warranty

This warranty policy applies to wood-burning products identified by Jøtul trade names, as set forth below.

A. LIMITED LIFETIME WARRANTY, parts only -

Jøtul North America Inc. (JØTUL) warrants, to the original retail purchaser, that those baffle and air manifold components of the Jøtul or Scan Stove or Fireplace Insert specified above will be free of defects in material and workmanship for the life of the product. This warranty is subject to the terms, exclusions and limitations set forth below.

B. LIMITED FIVE YEAR WARRANTY - Cast Iron and Steel Components:

JØTUL warrants, to the original retail purchaser, that those components of the Jøtul or Scan Stove or Fireplace Insert specified above will be free of defects in material and workmanship for a period of five (5) years from the date of purchase. This warranty is subject to the terms, exclusions and limitations set forth below.

C. LIMITED TWO YEAR WARRANTY - Enamel Finish:

JØTUL warrants, to the original retail purchaser, the enamel finish on cast iron components of the Jøtul Stove or Fireplace Insert specified above against peeling or fading for a period of two (2) years from the date of purchase. This warranty is subject to the terms, exclusions and limitations set forth below.

D. LIMITED ONE YEAR WARRANTY - Electrical Components (blowers, thermostatic switches):

JØTUL warrants, to the original retail purchaser, that those components of the Jøtul or Scan Stove or Fireplace Insert specified above will be free of defects in material and workmanship for a period of one (1) year from the date of purchase. This warranty is subject to the terms, exclusions, and limitations set forth below:

JØTUL will repair or replace at its option, any of the above components determined by JØTUL to be covered by this warranty. You must, at your own expense, arrange to deliver or ship the component to an authorized Jøtul dealer and arrange for pickup or delivery of the component after repairs have been made. If, upon inspection, JØTUL determines that the component is covered by this warranty, the repair or replacement will be made as set forth above. This warranty is not transferable and is extended only to, and is solely for the benefit of, the original retail purchaser of the Jøtul Stove or Fireplace Insert. This paragraph sets forth the sole remedy available under this warranty in the event of any defect in the Jøtul Stove or Fireplace Insert.

The warranty period for any replaced component will be the remaining unexpired portion of the warranty period for the original component.

Please retain your dated sales receipt in your records as proof of purchase.

EXCLUSIONS AND LIMITATIONS

NOTICE: This warranty is void if installation or service is performed by someone other than an authorized installer or service agency, or if installation is not in conformance with the installation and operating instructions contained in this owners manual or local and/or national fire and building regulations. A listing of local authorized installers, service agencies and gas suppliers can be obtained from the National Fireplace Institute at <http://www.nficertified.org/>.

This warranty does not cover the following:

- 1) Repair or replacement of parts that are subject to normal wear and tear during the warranty period or to parts that may require replacement in connection with normal maintenance. These parts include paint, gaskets, burn plates, firebricks, fire grates, ceramic insulation blankets or glass (glass is only warranted against thermal breakage).
- 2) Damage due to incorrect installations not in conformance with the installation instructions contained in this owners manual or local and/or national fire and building regulations.

- 3) Damage, including damage to enamel surfaces, caused by improper operation, over-firing, and/or misuse. Improper operation, such as burning the stove with the ash door open, can damage the stove. Over-firing occurs when any part of the stove glows red. Over-firing can also be identified by warped plates, rust-colored cast iron, paint pigment that has turned dusty white, or bubbling, cracking and discoloration of the enamel finish. Misuse includes, without limitation, use that is not in conformance with the operating instructions contained in this owners manual.
- 4) Damage due to, or repair of, rust. Use of stove-top steamers may cause rust.
- 5) Damage due to service performed by an installer or service agency, unless otherwise agreed to in writing by JØTUL.
- 6) Damage caused by unauthorized modification, use or repair.
- 7) Costs incurred by travel time and/or loss of service.
- 8) Labor or other costs associated with the repair of components beyond the warranty period.
- 9) Damage incurred while the Jøtul Stove or Fireplace Insert is in transit.

IN NO EVENT SHALL JØTUL, ITS PARENT COMPANY, SHAREHOLDERS, AFFILIATES, OFFICERS, EMPLOYEES, AGENTS OR REPRESENTATIVES BE LIABLE OR RESPONSIBLE TO YOU FOR ANY SPECIAL, INDIRECT, INCIDENTAL, CONSEQUENTIAL, PUNITIVE OR OTHER SIMILAR DAMAGES, INCLUDING, BUT NOT LIMITED TO, LOST PROFITS, LOST SALES, INJURY TO PERSON OR PROPERTY, OR DAMAGES TO A STRUCTURE OR ITS CONTENTS, ARISING UNDER ANY THEORY OF LAW WHATSOEVER. ALL IMPLIED WARRANTIES, INCLUDING THE IMPLIED WARRANTIES OF MERCHANTABILITY AND FITNESS FOR A PARTICULAR PURPOSE, OR OTHERWISE, ARE LIMITED IN DURATION TO THE LENGTH OF THIS WRITTEN WARRANTY. EXCEPT AS EXPRESSLY SET FORTH HEREIN, JØTUL MAKES NO ORAL, WRITTEN OR OTHER WARRANTY WITH RESPECT TO JØTUL OR SCAN STOVES OR FIREPLACES.

Some states do not allow the exclusion or limitation of incidental or consequential damages, or limitations on the length of implied warranties. Therefore, the above exclusions or limitations may not apply to you. This warranty gives you specific legal rights, and you may have other rights, which vary from state to state.

JØTUL reserves the right to discontinue, modify or change the materials used to produce the Jøtul Stove or Fireplace. JØTUL shall have the right to replace any defective component with substitute components determined by JØTUL to be of substantially equal quality and price.

The dollar value of JØTUL's liability for breach of this warranty shall be limited exclusively to the cost of furnishing a replacement component. JØTUL shall not in any event be liable for the cost of labor expended by others in connection with any defective component. Any costs or expenses beyond those expressly assumed by JØTUL under the terms of this warranty shall be the sole responsibility of the owner(s) of the Jøtul Stove or Fireplace Insert.

No dealer, distributor, or other person is authorized to modify, augment, or extend this limited warranty on behalf of JØTUL. NO MODIFICATION OR CHANGE TO THIS WARRANTY WILL BE EFFECTIVE UNLESS IT IS MADE IN A WRITTEN DOCUMENT MANUALLY SIGNED BY AN AUTHORIZED OFFICER OF JØTUL.

An authorized installer may have been provided with certain information related particularly to the Jøtul Stove or Fireplace Insert; however, no authorized installer or other person who may service the appliance is an agent of JØTUL. No inference should be made that JØTUL has tested, certified, or otherwise pronounced any person as qualified to install or service the appliance. JØTUL shall not be liable or otherwise responsible for any error or omission by a person installing or servicing a Jøtul Stove or Fireplace Insert.

If you believe your Jøtul or Fireplace Insert is defective, you should contact your nearest authorized Jøtul dealer, who will process a warranty claim. IN ORDER TO QUALIFY FOR WARRANTY COVERAGE, JØTUL MUST RECEIVE NOTICE OF A POSSIBLE DEFECT WITHIN SIXTY (60) DAYS OF THE DATE THE DEFECT IS FIRST DISCOVERED, OR REASONABLY COULD HAVE BEEN DISCOVERED.

This warranty is given by Jøtul North America, Inc.,
55 Hutcherson Drive, Gorham, Maine 04038 USA

This page is intentionally left blank

This page is intentionally left blank

This page is intentionally left blank

October 2024
139009

We appreciate your trust in welcoming our product into your home and invite your comment and appraisal of our efforts to provide you with the finest in home hearth products.

Jøtul pursues a policy of continuous product development. Products supplied may therefore differ in specification, colour and type of accessories from those illustrated and described in this manual.



Jøtul North America Inc.
P.O. Box 1157
55 Hutcherson Drive
Gorham, Maine 04038
USA

Jøtul AS
P.O. Box 1411
N-1602 Fredrikstad,
Norway

www.jotul.us