



Jøtul GF 160 DV IPI Direct Vent Gas Stove

Pilot-on-Demand Ignition

Installation and Operation Instructions

Certified to ANSI Z21.88-2019 • CSA 2.33-2019
and CAN/CGA 2.17-M17.

INSTALLER: Leave this manual with the appliance.
OWNER: Retain this manual for future reference.

WARNING: If the information in these instructions is not followed exactly, a fire or explosion may result causing property damage, personal injury or loss of life.

- Do not store or use gasoline or other flammable vapors and liquids in the vicinity of this or any other appliance.
- **WHAT TO DO IF YOU SMELL GAS**
 - Do not try to light any appliance.
 - Do not touch any electrical switch; do not use any phone in your building.
 - Leave the building immediately.
 - Immediately call your gas supplier from a neighbor's phone. Follow the gas supplier's instructions.
 - If you cannot reach your gas supplier, call the fire department.
- Installation and service must be performed by a qualified installer, service agency or the gas supplier.
- In the Commonwealth of Massachusetts, a carbon monoxide (CO) detector shall be installed in the same room as the appliance.

This appliance may be installed in an aftermarket, permanently located, manufactured home or mobile home, where not prohibited by local codes.

This appliance is only for use with the types of gas indicated on the rating plate. A conversion kit is supplied with the appliance.

! DANGER



**HOT GLASS WILL
CAUSE BURNS.
DO NOT TOUCH GLASS
UNTIL COOLED.
NEVER ALLOW CHILDREN
TO TOUCH GLASS.**

A barrier designed to reduce the burn hazard from the hot viewing glass is provided with this appliance and must be installed for the protection of children and other at-risk individuals.

THIS OWNER'S MANUAL PROVIDES INFORMATION TO ENSURE SAFE INSTALLATION AND EFFICIENT, DEPENDABLE OPERATION. PLEASE READ THESE INSTRUCTIONS IN THEIR ENTIRETY AND MAKE THEM AVAILABLE TO ANYONE USING OR SERVICING THE APPLIANCE.

DO NOT ATTEMPT TO ALTER OR MODIFY THE CONSTRUCTION OF THIS APPLIANCE OR ITS COMPONENTS. ANY MODIFICATION OR ALTERATION WILL VOID THE WARRANTY, CERTIFICATION AND LISTING OF THIS APPLIANCE.

THIS APPLIANCE MUST BE INSTALLED AND MAINTAINED BY A QUALIFIED SERVICE TECHNICIAN OR AGENCY.

Suggested Tools for Installation and Service

- External regulator (for Propane only)
- Piping which complies with local code
- Manual shut-off valve -
T-Handle required in Massachusetts
- Sediment trap - if required by code
- Tee joint
- Pipe wrench
- Pipe sealant
- 10 mm open end wrench
- 1/2", 7/16" open end wrench
- Phillips head screwdriver
- Flat head screwdriver
- 1/4" nut driver
- Gloves
- Safety glasses
- Torx T-20 screwdriver for
Fuel Conversion

PLEASE NOTE:

Initial Break-in

It is normal for smoke and odor to occur during the initial stages of operation, depending upon temperatures generated over time. This "curing" condition can be alleviated by promoting fresh air circulation within the immediate vicinity of the appliance. Please see page 23 for further information.

Operation Sound

Please be aware that cast iron and steel components expand and contract with temperature fluctuations that are often accompanied by "creaking" or "pinging" sounds. This is the result

of natural thermal activity. The optional blower fan will also generate a slight hum at the low setting and progressively increase with the velocity of forced air.

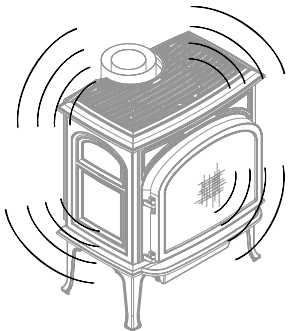

Installation Requirements for the Commonwealth of Massachusetts

THIS PRODUCT MUST BE INSTALLED BY A LICENSED MASTER OR JOURNEYMAN PLUMBER OR GAS-FITTER WHEN INSTALLED IN THE COMMONWEALTH OF MASSACHUSETTS.

1. If there is not one already present, on each floor level where there are bedroom(s), a carbon monoxide detector and alarm shall be placed in the living area outside the bedroom(s). The carbon monoxide detector shall comply with NFPA 720 (2005 Edition).
2. A carbon monoxide detector shall:
 - a) Be located in the room that houses the appliance or equipment;
 - b) Be either hard-wired or battery powered or both; and
 - c) Shall comply with NFPA 720 (2005 Edition).
3. A Product-approved vent terminal must be used, and if applicable, a Product-approved air intake must be used. Installation shall be in strict compliance with the manufacturer's instructions. A copy of the installation instructions must remain with the appliance or equipment at the completion of the installation.
4. A Manual gas supply line shut-off valve must be installed.

**NATIONAL
FIREPLACE
INSTITUTE**



CERTIFIED
www.nficertified.org

We recommend that our gas products be installed and serviced by professionals who are certified in the U.S. by the National Fireplace Institute® (NFI) as NFI Gas Specialists.

Canada

ENERGUIDE

Gas Fireplace Energy Efficiency Rating

Natural Gas / 67.91%
Propane / 68.53%

Based on CSA P.4.1-15

Model No. Jøtul GF 160 DV IPI



Table of Contents

| | |
|--------------------------------------|-------|
| 1. Specifications..... | 4 |
| 2. Initial Assembly | 5 |
| 3. General Information..... | 6 |
| 4. Safety Information | 6 |
| 5. Installation Requirements..... | 7 |
| Floor Protection | 7 |
| Clearances | 7-8 |
| 6, Vent Requirements | 9 |
| Vertical Termination..... | 11 |
| Horizontal Termination..... | 11-13 |
| 7. Fuel Conversion | 14-18 |
| 8. Gas Connection | 18 |
| 9. Gas Pressure..... | 19 |
| 10. High Altitude Adjustment | 19 |
| 11. Optional Equipment | 20 |
| Firebox Panel Kits | 20 |
| 12. Burner Media Installation | |
| Log Set | 21 |
| River Rocks | 22 |
| Tumbled Stones..... | 22 |
| Glass | 22 |
| 13. System Check | 23 |
| 14. Flame Picture Adjustment | 24 |
| 15. Operation Guidelines..... | 25 |
| Manual Operation..... | 26 |
| Remote Control | 27-30 |
| 16. Maintenance | 31 |
| Annual Cleaning | 31 |
| Glass Care & Replacement | 31 |
| Safety Screen Replacement | 33 |
| Battery Replacement | 34 |
| 17. Appendix | 35 |
| Wiring Diagram | 35 |
| Illustrated Parts Lists | 36-39 |
| Mobile Home Requirements | 40 |
| Burner Flame Pattern References..... | 41 |
| Beach Fire Logset Installation..... | 42-43 |
| 18. Warranty Statement | 44 |
| 19. Lighting Instructions | 45 |

Jøtul GF 160 DV IPI (POD)

Direct Vent Gas Heater

Manufactured and Distributed by:
 Jøtul North America
 55 Hutcherson Dr.
 Gorham, Maine 04038

Certified Test Standards

This appliance complies with National Safety standards and is tested and listed by

Intertek Testing Services of Middleton, Wisconsin to ANSI Z21.88-2019 • CSA 2.33-2019, “Vented Gas Fireplace Heater” and CAN/CGA 2.17-M17.



WARNING:

READ AND UNDERSTAND ALL OPERATING INSTRUCTIONS BEFORE ATTEMPTING TO OPERATE THIS APPLIANCE. DO NOT ALLOW ANYONE TO OPERATE THIS APPLIANCE WHO HAS NOT READ AND UNDERSTOOD THESE INSTRUCTIONS.

KEEP THE REMOTE CONTROL TRANSMITTER WHERE CHILDREN CANNOT REACH IT.



WARNING:

SEVERE INJURY. THIS APPLIANCE CAN BE SET TO OPERATE THERMOSTATICALLY. BE AWARE THAT THE STOVE MAY BE VERY HOT EVEN WHEN THE BURNER IS NOT APPARENTLY OPERATING.

KEEP CHILDREN AWAY FROM THE APPLIANCE.



WARNING:

FIRE HAZARD. CAN CAUSE SEVERE INJURY OR DEATH. THE APPLIANCE CAN TURN ON SUDDENLY. KEEP AWAY FROM THE APPLIANCE BURNER WHEN OPERATING THE REMOTE SYSTEM.

1. Specifications

Input Rates

Natural Gas

15,800 BTU/hr. minimum input
24,000 BTU/hr. maximum input

Propane

19,800 BTU/hr. minimum input
24,000 BTU/hr. maximum input

| Inlet Pressure: | MIN | MAX |
|-----------------|-------------------|--------------------|
| Natural Gas: | 5.0 WC (1.25 kPa) | 7.0 WC (1.74 kPa) |
| Propane: | 11.0 WC (3.0 kPa) | 14.0 WC (3.48 kPa) |

| Manifold Pressure: | MIN | MAX |
|--------------------|-------------------|--------------------|
| Natural Gas: | 1.6 WC (.40 kPa) | 3.50 WC (.87 kPa) |
| Propane: | 6.4 WC (1.59 kPa) | 10.0 WC (2.49 kPa) |

- SIT Proflame 2 Intermitent Pilot Ignition - 120V / 60 Hz
- Steady State Efficiency: 74.49% NG / 74.18% LP
- AFUE Efficiency: 66.60% NG / 66.40% LP
- CSA P4. 1-15 Fireplace Efficiency:
NG - 67.91% LP - 68.53%
- Factory Air Shutter Open Settings: NG - 0" LP - 1/16"
- Continuous Pilot Ignition Mode (CPI) is available
- Power Requirement: 120 VAC
Back-up Battery Pack: 4, AA - 1.5v ea.
- Ambient Temperature Range: 32 -122°F (0 - 50°C)

Miscellaneous Hardware Bag Contents

- Fuel Conversion Kit , LP 158057
- Rock Wool Embers, 1 oz. 157259
- 1.5v AA Alkaline Batteries, 4 224109
- Remote Control Transmitter 157495
- Remote Transmitter Wall Bracket 223951BKP
- Door Adjustment Washers, 3 117587
- GF 160 DV IPI Manual 139894
- Top Plate Grill, 2 : Matte Black 22299592
- Touch-up Paint, Enamel (*Enamel only*)

Options & Accessories

- Log Set 158045
- Tumbled Stones 158054
- Beach Fire Logset..... 158229
- River Rock Set..... 158055
- Clear/White Glass 156815
- Black Glass 157342
- Skamol Panel Set 158046
- Black Reflective Panel Set 157965
- Fuel Conversion Kit , LP 158057
- Fuel Conversion Kit, NG - 158058
- High Altitude Adjustment Kit, LP 158059
- High Altitude Adjustment Kit, NG 158060
- Mobile Home Leg Bracket Kit 158074

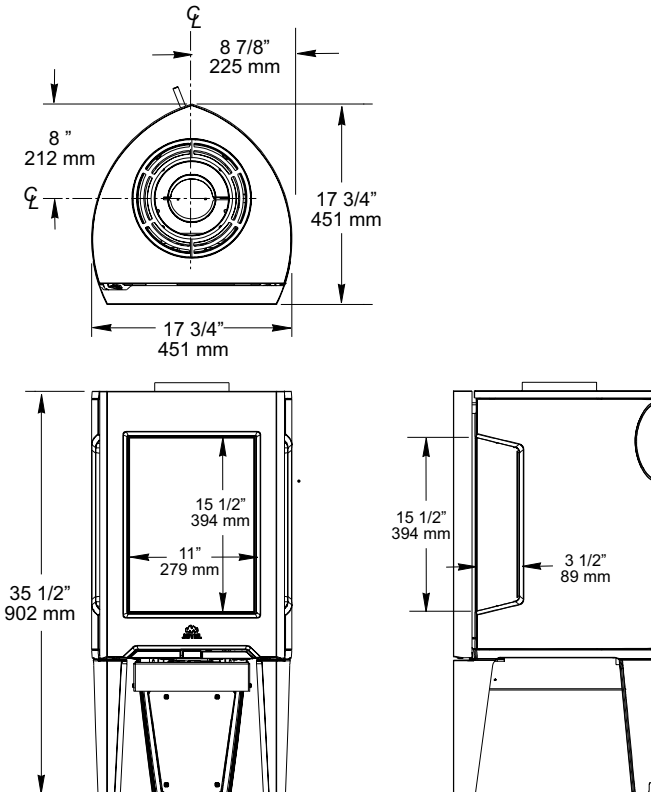



Figure 1.1 Dimensioned views, GF 160 DV IPI



SAFETY BARRIER SCREEN
The front door and side glass panels of this appliance are equipped with integrated Certified Safety Barrier Screens which must remain installed at all times. Should a screen become damaged, contact your authorized Jøtul dealer for original equipment replacement assemblies.

2. Initial Assembly

STOP! FOR EASIEST ACCESS, INSTALL FUEL CONVERSION AND FIREBOX PANELS BEFORE REMOVING THE STOVE FROM THE PALLET.



CAUTION: Enamel parts may be damaged if handled without care. The stove is heavy. **DO NOT DRAG THE STOVE LEGS.**

Have assistance available to move the stove into position. Place removed parts on a blanket, towel, or other protective material.

Unpacking the Stove

EXCEPT AS NOTED, ALL INSTRUCTIONS ARE ORIENTED FACING THE FRONT OF THE STOVE.

1. ENAMEL STOVE ONLY:

- Lift the top plate from the stove.
- Remove and discard the door-stop bolt from the hinge bar as shown in fig. 2.1.

2. Open the Firebox

- The front door swings open to the left. Grasp it from the right side or lower edge.
- Lift the Top Plate Grills and Top Plate from the stove and set aside.
- Remove the Latch Tool from the shipping pallet and use it to remove the Glass Panel by pulling the two latch hooks out to disengage them from the glass frame. Fig. 2.2.
- Tilt the glass frame forward, then lift it straight up and off of the stove.

3. Remove the Miscellaneous Hardware kit from the firebox and inspect the contents. Refer to the list on the previous page and contact your dealer if any items are missing.

4. Install Backup Batteries: Four AA batteries are supplied in the Miscellaneous Kit. The battery box is located in the left side of the controls compartment. Orient battery polarity (+ -) as designated on the box label. See also fig. 16.4, page 33.

Remote Transmitter: Install 3 AAA batteries supplied into the hand-held transmitter unit. The transmitter and appliance have been synchronized at the factory.

5, Optional Equipment and Burner Media: See Sections 11 and 12 for specific installation instructions.

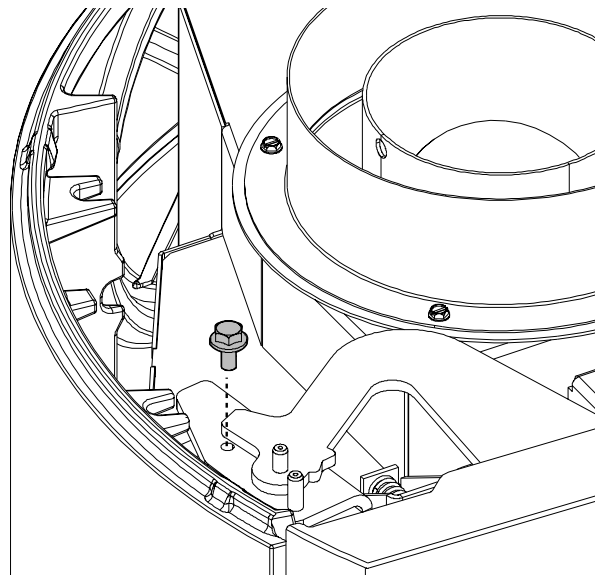

Figure 2.1 Enamel stoves:
Use a 10mm wrench to remove the door-stop bolt.

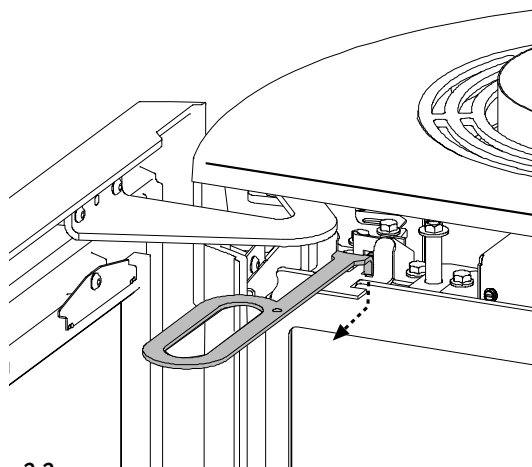

Figure 2.2
Disengage the glass frame latches to open the firebox.

RE-INSTALL THE TOP PLATE BEFORE CONNECTING VENT PIPE TO THE STOVE.

3. General Information

■ THIS HEATER MUST BE INSTALLED AND MAINTAINED BY A QUALIFIED SERVICE AGENCY.

■ The installation and repair of this appliance must be done by a qualified service person. Failure to properly install and maintain this heater could result in an unsafe or hazardous installation, which may result in a fire, explosion, property damage, personal injury or loss of life.

■ This appliance should be inspected before use and at least annually. More frequent cleaning may be required due to excessive lint from carpeting, bedding material, etc. It is imperative that control compartments, burners, and circulating air passageways of the appliance be kept clean. See Maintenance section for details.

■ THIS APPLIANCE MUST NOT BE CONNECTED TO A CHIMNEY OR FLUE SERVING ANY OTHER APPLIANCE.

■ The installation must conform to local codes. Your local Jøtul dealer can assist you in determining what is required in your area for a safe and legal installation. Some areas require a permit to install a gas burning appliance. Always consult your local building inspector, or authority having jurisdiction, to determine what regulations apply in your area.

■ **CODE COMPLIANCE** : Your local officials have final authority in determining if a proposed installation is acceptable. Any requirement that is requested by the local authority having jurisdiction, that is not specifically addressed in this manual, defaults to local code. In the absence of local codes, the installation requirements must comply with the current edition of National codes. In the U.S., these requirements are established in the National Fuel Code, ANSI Z223.1.(NFPA 54) current edition. In Canada, the codes have been established in CAN/CGA B149 Fuel Installation Code, current edition.

■ The appliance, when installed, must be electrically grounded in accordance with local codes or, in absence of local codes, with the National Electrical Code, ANSI/NFPA 70, or the Canadian Electrical Code, CAN/CSA C22.1.

■ **CAUTION:** Label all wires prior to disconnection when servicing controls. Wiring errors can cause improper and dangerous operation.

Verify operation after servicing.

■ **DO NOT OPERATE THIS STOVE IF ANY PART HAS BEEN UNDER WATER.** Call a qualified service technician to inspect the heater and to replace any part of the control system and any gas control which may have been under water.

4. Safety Information

■ Due to the high operating temperatures this appliance should be located out of traffic and away from furniture and draperies. Maintain proper clearance to combustible mantels and fireplace trim.

■ Children and adults should be alerted to the hazards of high surface temperatures and should stay away to avoid burns or clothing ignition.

■ Young children should be supervised while they are in the same room as the appliance. Toddlers, young children and others may be susceptible to accidental contact burns. A physical barrier, such as a child guard, is recommended to be used if there are at-risk individuals in the house. To restrict access to a fireplace or stove, install an adjustable safety gate to keep toddlers, young children and other at-risk individuals out of the room and away from hot surfaces.

■ This appliance includes permanent, integrated safety barriers designed to reduce the risk of burns from the hot viewing glass. These barriers shall remain installed for the protection of children and other at-risk individuals.

The appliance must not be operated with the front door open or ajar.

■ A damaged screen barrier must be replaced only with Jøtul GF 160 Front Replacement Screen 158062, or Side Replacement Screen 158063, available from any Jøtul Authorized Dealer.

■ Any safety screen, guard, or barrier removed for servicing an appliance must be replaced prior to operating the appliance. See maintenance instructions.

■ Clothing or other flammable materials should not be placed on or near the fireplace.

■ Never allow anyone to use the fireplace if they are unfamiliar with its operation.

■ NEVER store or use gasoline or any other flammable vapors or liquids in the vicinity of this appliance.

■ Never burn any solid materials (wood, cardboard, paper, coal, etc.) in this appliance. Use with natural gas or propane fuel ONLY.

■ Do not slam or strike the glass panel.

■ This appliance is NOT for use with aftermarket glass doors.

■ Wear gloves and safety glasses while installing or performing maintenance procedures on this appliance.

5. Installation Requirements

Location

In selecting a location for the stove, consider the following points:

- 1) Heat distribution
- 2) Vent termination requirements
- 3) Gas supply line routing
- 4) Traffic areas, furniture, draperies, etc.

The stove may be located on or near conventional construction materials, however, proper clearance to combustibles must be maintained in order to provide adequate air circulation around the appliance. Also, it is important to provide adequate access around the stove for servicing and operation.

The clearance and hearth specifications listed in this manual are the minimum requirements for combustible material. A combustible material is anything that can burn (i.e. sheet rock, wall paper, wood, fabrics etc.). These surfaces are not limited to those that are visible and also include materials that may be located behind non-combustibles.

If you are not sure of the combustible nature of a material, consult your local fire officials. Remember, "Fire Resistant" materials are considered combustible: they are difficult to ignite, but will burn. Also, "fire-rated" sheet rock is considered combustible.

Floor Protection

This appliance **MAY NOT** be installed directly on carpeting, vinyl, or linoleum. If this appliance will be installed on any combustible material **OTHER THAN WOOD**, a floor pad must be installed that is either metal, wood, ceramic tile, stone, or a listed hearth pad. This floor protection must extend the full width and depth of the appliance. It is not necessary to remove carpeting, vinyl, linoleum or laminate from underneath the floor protection. See fig. 5.1.

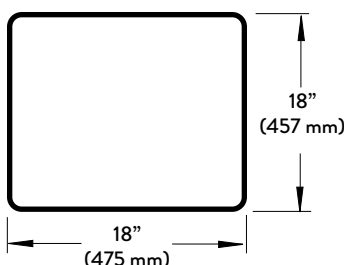

Figure 5.1. Minimum combustible floor protection.

Stove and Vent Clearance Requirements

Minimum Clearances from the Stove to Combustibles:

| | | Measured from: |
|----------|------------------|----------------|
| Rear: | 2" (51 mm) | Rear Shroud |
| Ceiling: | 33 1/2" (850 mm) | Top Plate |
| Corner: | 3 3/8" (86 mm) | Side Plate |
| Side: | 7 3/8" (178 mm) | Side Plate |

Minimum Clearances between Vent Pipe and Combustible Materials:

Horizontal Run:

| | |
|--------------------------|------------|
| Off the top of the pipe | 2" (51 mm) |
| Off the sides and bottom | 1" (25 mm) |

Vertical Run:

| | |
|-----------|------------|
| All sides | 1" (25 mm) |
|-----------|------------|

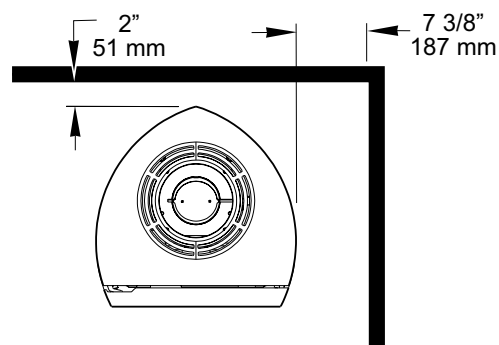

Figure 5.2. Parallel Clearances

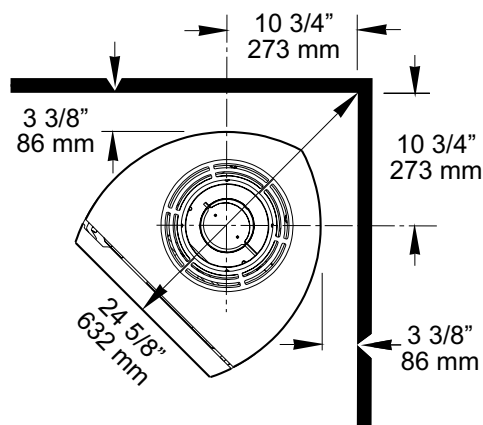

Figure 5.3. Corner Wall clearances.

Alcove Installation

- Maximum Alcove Depth: 24" (607 mm)
- Minimum Alcove Width*: 32 1/2" (826 mm)
- Minimum Alcove Ceiling Height from floor: 69" (1752 mm)

* Alcove clearances are determined through testing in specific construction configurations which often result in greater clearances than an open stove installation.

Clearance to Combustible Materials Above Stove

Minimum Mantle Height from floor: 46 3/4" (118.74 cm) with 24" (610 mm) maximum mantle depth.

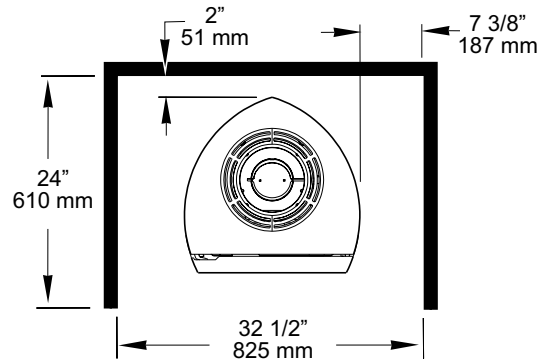

Figure 5.4 Alcove Clearances.

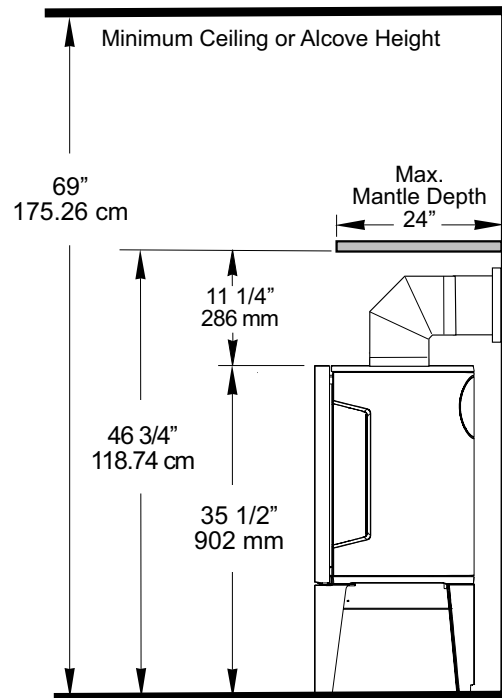

Figure 5.5. Mantel and Ceiling Clearances.

6. Venting Requirements

The Jøtul GF 160 DV IPI gas stove may be installed with a vertical or horizontal termination and must conform to the configuration requirements described below.

This appliance is approved for use with vent systems from the following manufacturers:

- M&G DuraVent DirectVent Pro and GS Series
- American Metal Products (Amerivent)
- Security Chimneys International, Ltd. (Secure Vent)
- Selkirk Metalbestos (Direct Temp)
- Metal-Fab, Inc. (Sure-Seal Direct Vent)
- Industrial Chimney Corp. (ExcelDirect)
- Bernard Dalsin Mfg. (Pro Form)
- Olympia Chimney Supply, Inc. (Ventis Direct Vent)

Use parts of one manufacturer only - DO NOT MIX VENT COMPONENTS FROM DIFFERENT MANUFACTURERS IN THE SAME SYSTEM.

Installation of any components not manufactured or approved by Jøtul or failure to meet all clearance requirements will void all warranties and could result in property damage, bodily injury, or serious fire.

The approved vent configurations described in this manual are derived from extensive testing under controlled laboratory conditions. Gas appliance performance can be negatively affected by variables present in the installation environment, i.e: atmospheric pressure, strong prevailing winds, adjacent structures and trees, snow accumulation, etc. These conditions should be taken into consideration by the installer and stove owner when planning the vent system design.

IMPORTANT

- **JOINT SEALING REQUIREMENT: APPLY A 1/8" BEAD OF HIGH-TEMPERATURE SEALANT OR MIL-PAC® TO THE MALE SECTION OF THE INNER VENT PIPE. THE CEMENT SHOULD FORM A SEAL BETWEEN THE INNER AND OUTER PIPES.**
- **NEVER MODIFY ANY VENTING COMPONENT, OR USE ANY DAMAGED VENTING PRODUCT.**
- **THE GAS APPLIANCE AND VENT SYSTEM MUST BE VENTED DIRECTLY TO THE OUTSIDE OF THE BUILDING AND NEVER ATTACHED TO A CHIMNEY SERVING A SOLID FUEL OR GAS BURNING APPLIANCE. EACH DIRECT VENT GAS APPLIANCE MUST HAVE ITS OWN SEPARATE VENT SYSTEM. COMMON VENT SYSTEMS ARE PROHIBITED.**
- **IF THE VENTING SYSTEM IS DISASSEMBLED FOR MAINTENANCE OR ANY OTHER REASON, IT MUST BE PROPERLY REASSEMBLED AND RESEALED IN ACCORDANCE WITH THE ORIGINAL VENT MANUFACTURER'S INSTRUCTIONS.**

**CONFIRM THAT ALL INTERLOCKING JOINTS ARE TIGHTLY RE-SECURED AND THAT ALL SEALS ARE MAINTAINED INTACT.
REINSTALL ANY FASTENERS AND REPLACE AS NECESSARY.**

Figure 6.1.
DO NOT USE SILICONE SEALANT.

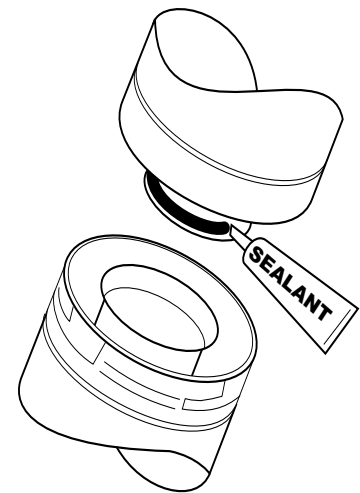

RE-INSTALL THE TOP PLATE BEFORE CONNECTING VENT TO THE STOVE.

Vent Restriction

The GF 160 DV IPI is equipped with an Exhaust Restrictor Plate which enables regulation of the exhaust gas flow. The plate prevents overly-strong draft that can cause poor combustion and weak flame picture. **Follow the guidelines below and on the following pages to determine the correct restrictor plate setting for your particular installation.**

Exhaust Restrictor

The Exhaust Restrictor plate is located within the firebox exhaust outlet. It is adjusted by rotating the dial on the right side of the outlet within a range beginning at the factory-set, fully open position (no restriction) to a fully restricted position. See Figs. 6.2 and 6.3. The Minus (-) and Plus (+) signs on the dial relate to degrees of restriction, from zero to approximately 70%. The four, lettered positions correlate to the termination zones (A,B,C,D) diagramed in figure 6.4. Use the diagram to determine the degree of restriction and shutter setting that correlates to your vent configuration.

Adjusting Exhaust Restrictor Plate:

1. Use a 10 mm open-end wrench to loosen the lock nut and then use the pivot tab to set the dial to the position appropriate to your termination zone. See figs. 6.2-6.4, page 10.
2. Re-tighten the lock nut after adjustment.

Approved Horizontal and Vertical Vent Terminations

- **NOTE:** Long vertical vent runs (over 12 ft.) in uninsulated air space may require the stove be operated in CPI mode for best performance.
- **ALL VENTING MUST TERMINATE (END) WITHIN ONE OF THE DESIGNATED AREAS.**
- **SET STOVE EXHAUST RESTRICTOR TO THE POSITION THAT CORRESPONDS TO THE VENT TERMINATION AREA IN THE MATRIX.** When termination is exactly on a division line, use the less restrictive position. For example, if termination is 10 feet high and offset 7 feet, restriction should be set at Position B.
- Up to two 45° elbows or one additional 90° elbow is permitted in addition to the first elbow, however, a 5 foot reduction in horizontal length must be made for each additional elbow whether 45° or 90°.

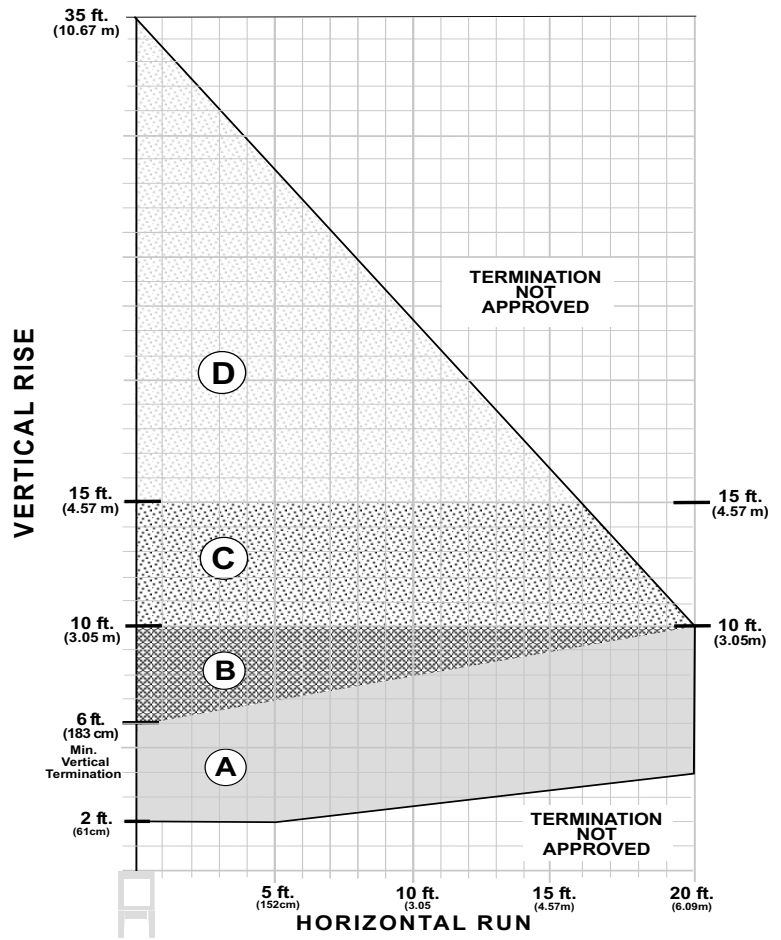

Figure 6.2.
Vent Termination Restriction Zones - NG / LP.
See also Snorkel Termination vent run restrictions, pg. 12.

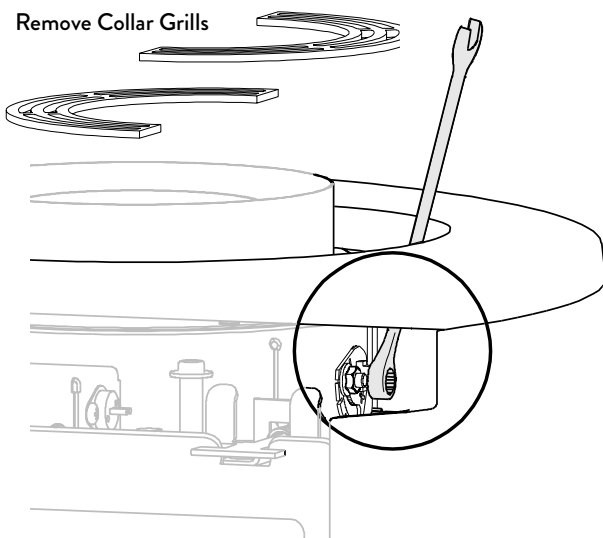

Figure 6.3.
Use a 10 mm wrench to loosen the Restrictor lock nut.

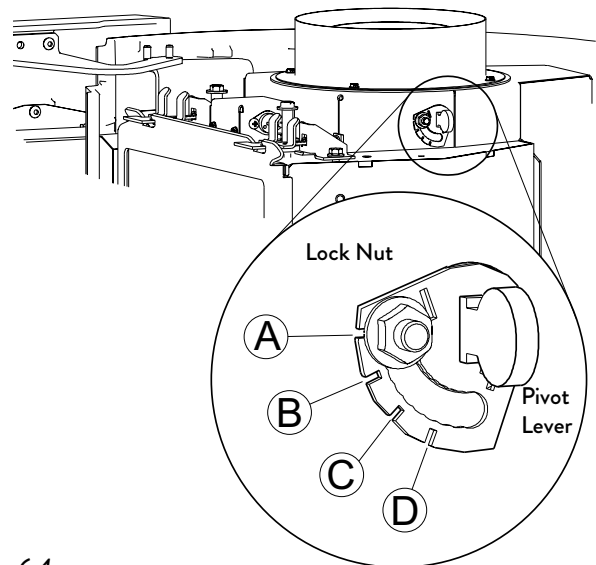

Figure 6.4.
Determine the dial notch position appropriate to your vent configuration as designated in Fig 6.2. Pivot the dial to align the lock nut with that notch.

Vertical Vent Termination

This appliance may be vertically vented through a ceiling or to a roof termination using the following guidelines:

- The termination should fall within the shaded areas of the grids depicted in the Vent Matrix, fig. 6.2, page 10.
- **Maximum Horizontal run is 20 ft. (152 cm)** See Fig. 6.2 for related termination zone limitations.
- **Minimum Vertical Termination is 6 ft. (183 cm).**
- **Total run, including offsets, must not exceed 35 ft. (10.67m).**
- **Vent Terminus Clearance:** In no case shall any discharge opening on the cap be less than 18 in. (457 mm) horizontally from the roof surface. See fig. 6.5.
- Steep roofs, nearby trees, and predominantly windy conditions can contribute to poor draft and/or promote draft reversal. Increasing the height of the vent may alleviate these conditions.
- Use Wall Straps to support an offset pipe run at intervals of three feet to avoid excessive stress on the offsets.
- A firestop is required at every floor. The floor opening should be framed to 10" X 10" inside dimension.
- Any venting that is exposed in living space above the first floor must be enclosed. Always maintain the required 1" clearance from all sides of the vertical vent system. Insulation in attic space must be retained by an insulation barrier.

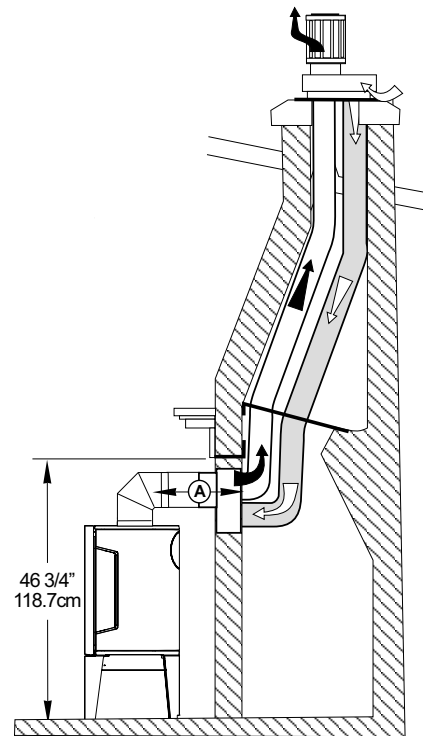

Figure 6.6. Co-linear Termination is permitted with 2 foot (62 cm) maximum horizontal run (A).

RE-INSTALL THE TOP PLATE BEFORE CONNECTING VENT TO THE STOVE.

FUNCTIONALITY NOTE:

LONG, VERTICAL VENT CONFIGURATIONS MAY REQUIRE THE APPLIANCE BE OPERATED IN CONTINUOUS PILOT MODE (CPI) TO ASSURE ADEQUATE DRAFT AND PROPER PERFORMANCE.

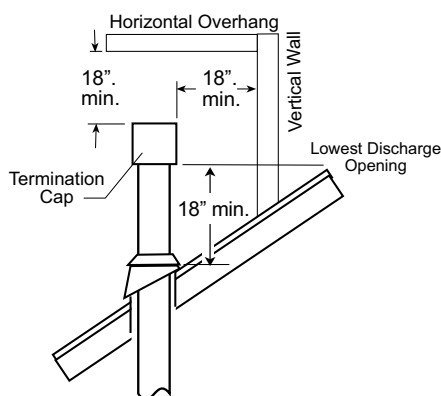

Figure 6.5. Vertical vent termination height above roof.

Horizontal Termination

- Any horizontal termination must fall within the shaded portion of the vent window matrix shown in fig. 6.2.
- Any horizontally-terminated vent run must include a minimum 24" (61 cm) vertical rise. See figs. 6.8, 6.9, 6.10.
- **Horizontal termination requirements:**
 - 1) Maximum vertical run is 35 ft. (10.67m)
 - 2) Maximum horizontal run is 20 ft. (6.1 m)
- **ELBOW RESTRICTION:** Up to two 45° elbows or one 90° elbow may be used in addition to the first elbow.
The horizontal run must be reduced by 5 feet for each additional elbow, whether 45° or 90°.
- **Wall Cut-out Opening:** A minimum 10" X 10" (250 mm x 250 mm) square hole is required for proper pipe clearances through a combustible wall.

Continued from page 11.

- **Horizontal Vent Pipe Clearance to Combustible Material:**
From Top Surface: 2" (51 mm)
From Sides: 1" (25 mm)

DO NOT FILL AIR SPACE WITH ANY TYPE OF INSULATION.

- Any horizontal run of vent must be level or have a 1/4 in. rise for every foot of run toward the termination cap. NEVER ALLOW THE VENTING TO RUN DOWNWARD FROM STOVE TO TERMINATION; A DOWNWARD VENT RUN TRAPS HEAT AND CREATES A FIRE HAZARD.

- The horizontal termination cap must maintain a 3" clearance to any overhead combustible projections 2 1/2" or less. It must also maintain 12" clearance from projections exceeding 2 1/2". See fig. 6.15.

- A direct vent terminal may not be recessed into a wall or siding.

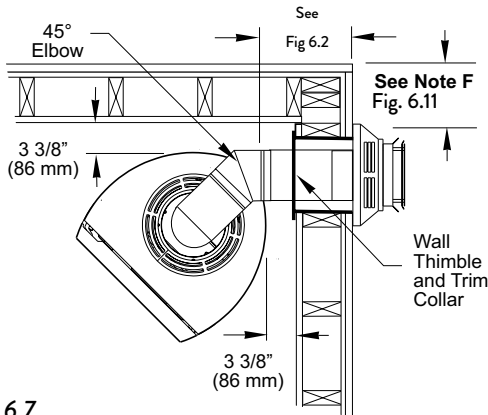

Figure 6.7. Horizontal termination clearance to exterior corner.

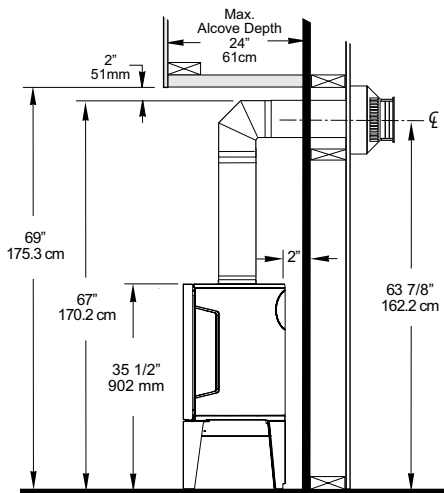

Figure 6.8. Minimum vent required for horizontal termination.

- Any horizontally terminated vent run must include a minimum 2 ft. (61 cm) vertical rise.
- At minimum vertical run, the total horizontal run (A) must not exceed 5 ft. (152.4 cm).

- Install a Vinyl Siding Standoff (M&G Dura-Vent #950) between the vent termination and an exterior wall covered by vinyl siding material to prevent potential heat damage to the siding.

SNORKEL TERMINATION:

- HORIZONTAL RUN MUST NOT EXCEED 2 FEET (61 CM).

A 14" (356mm) or 36" (914mm) snorkel termination is approved in conformance with the vent rise/run and termination clearance specifications published in this manual. See figs. 6.9 – 6.10.

The snorkel termination must comply with grade and building clearance requirements per local and national building codes.

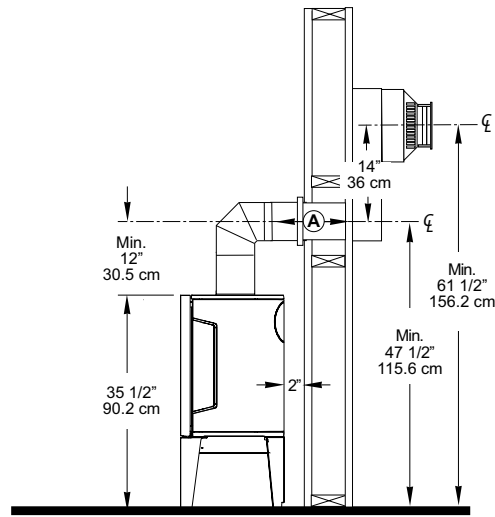

Figure 6.9. 14" Snorkel termination.

- 14" SNORKEL WILL REQUIRE 12" VENT OFF STOVE TO MEET MINIMUM RISE REQUIREMENT
- 2 FT. MAX. HORIZONTAL RUN (A) TO SNORKEL TERMINATION

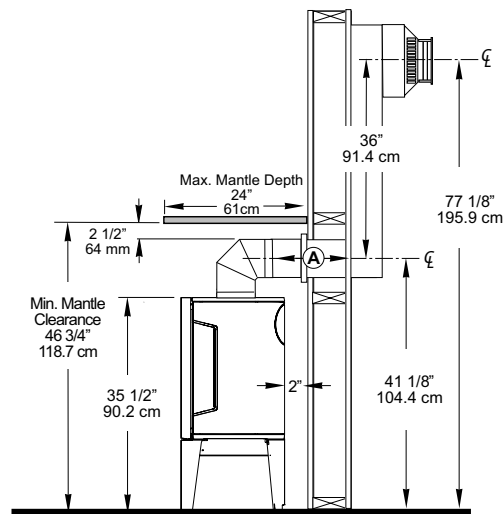

Figure 6.10. 36" Snorkel termination and mantle clearance.

- 2 FT. MAX. HORIZONTAL RUN (A) TO SNORKEL TERMINATION

Horizontal Termination Clearance Requirements

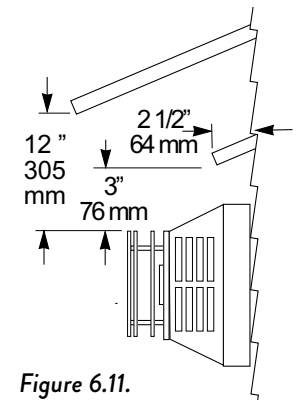
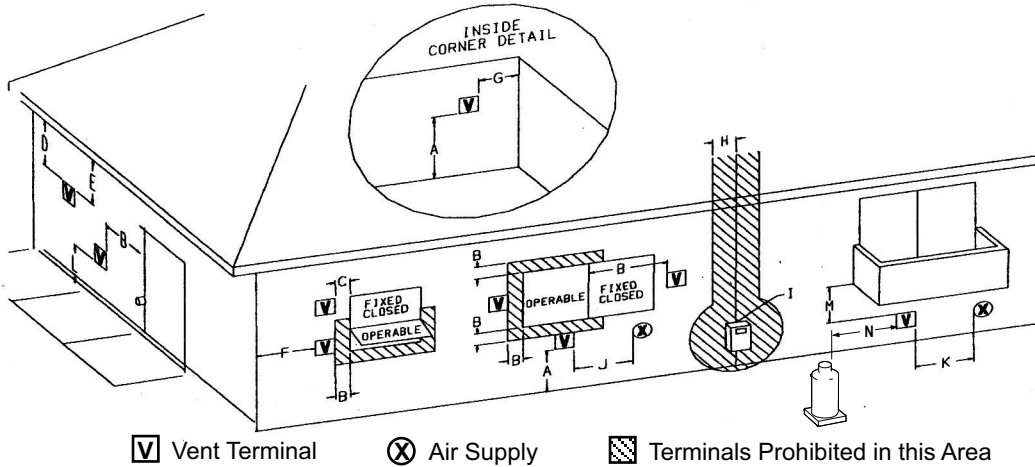

Figure 6.11. Termination Clearance to overhangs.

Figure 6.11. Vent Terminal Clearances, Canada and United States

| | | Canadian Installations ¹ | U.S. Installations ² |
|---|--|---|---|
| A | Clearance above grade, veranda, porch, deck, or balcony | 12 in. (30 cm) | 12 in. (30 cm) |
| B | Clearance to window or door that may be opened | 12 in. (30 cm) | 9 in. (23 cm) We recommend 12 in. to prevent condensation on a window. |
| C | Clearance to permanently closed window | 12 in. (30 cm) | 9 in. (23 cm) We recommend 12 in. to prevent condensation on a window. |
| D | Vertical clearance to ventilated soffit located above the terminal within a horizontal distance of 2 ft (60 cm) from the center line of the terminal | 18 in. (46 cm) | 18 in. (46 cm) |
| E | Clearance to unventilated soffit | 12 in. (46 cm) | 12 in. (46 cm) |
| F | Clearance to outside corner | 12 in. (46 cm) | 9 in. (23 cm) We strongly recommend 12 in. particularly where strong winds prevail. |
| G | Clearance to inside corner | 12 in. (46 cm) | 9 in. (23 cm) We strongly recommend 12 in. particularly where strong winds prevail. |
| H | Clearance to each side of center line extended above a gas meter or regulator | 3 ft. (91 cm) within a height 15 ft. above the meter/regulator assembly | * |
| I | Clearance to service regulator vent outlet | 3 ft. (91 cm) | * |
| J | Clearance to nonmechanical air supply inlet to building or the combustion air inlet to any other appliance | 12 in. (30 cm) | 9 in. (23 cm) |
| K | Clearance to a mechanical air supply inlet | 6 ft. (1.83 m) | 3 ft. (91 cm) above if within 10 ft. (3 m) horizontally |
| L | Clearance above paved sidewalk or paved driveway located on public property | 7 ft. (2.13 m) ³ | * |
| M | Clearance under veranda, porch, deck, or balcony | 12 in. (30 cm) ⁴ | 12 in. (30 cm) ⁴ |
| N | Clearance to propane tank relief valve and filler connection | 5 ft. (1.52 m) ⁵ / 10 ft. (3.05 m) ⁶ | 5 ft. (1.52 m) ⁵ / 10 ft. (3.05 m) ⁶ |

1) In accordance with the current CSA B149.1, Natural Gas and Propane Installation Code.

2) In accordance with ANSI Z223.1/NFPA 54, National Fuel Gas Code

* For clearances not specified in ANSI Z223.1/NFPA 54 or CSA B149.1, the clearance will be in accordance with local installation codes and the requirements of the gas supplier.

3) A vent shall not terminate directly above a sidewalk or driveway which is located between two single family dwellings and serves both dwellings.

4) Permitted only if veranda, porch, deck, or balcony is fully open on a minimum of two sides beneath the floor.

5) Minimum clearance to tanks not filled on site.

6) Minimum clearance to tanks filled on site from bulk truck.

7. Fuel Conversion

The GF 160 DV IPI gas stove is shipped from the factory equipped to burn NATURAL GAS only. If PROPANE gas is to be used as fuel, the appliance must first be converted by using the Propane Conversion Kit 158057 included with the stove. Use Natural Gas Conversion Kit 158058 to revert back to Natural gas.

WARNING:

THE CONVERSION KIT IS TO BE INSTALLED BY AN AUTHORIZED SERVICE TECHNICIAN IN ACCORDANCE WITH THE MANUFACTURER'S INSTRUCTION AND ALL CODES AND REQUIREMENTS OF THE AUTHORITY HAVING JURISDICTION. FAILURE TO FOLLOW THESE INSTRUCTIONS COULD RESULT IN SERIOUS INJURY OR PROPERTY DAMAGE. THE QUALIFIED AGENCY PERFORMING THIS WORK ASSUMES RESPONSIBILITY FOR THIS CONVERSION.

IN CANADA:

THE CONVERSION SHALL BE CARRIED OUT IN ACCORDANCE WITH THE REQUIREMENTS OF THE PROVINCIAL AUTHORITIES HAVING JURISDICTION AND IN ACCORDANCE WITH THE REQUIREMENTS OF THE CAN1-B149.1 AND .2 INSTALLATION CODE.

Tools required:

- 1/2" or 13 mm wrench or deep-well socket,
- Torx T20 screw driver
- 1/4" socket driver or spade screwdriver
- 7/16" open-end wrench
- Small pliers or vice-grip

Conversion Kit Contents:

- 1, regulator tower labeled LP
- LP orifice: 1.45 mm
- 1, Pilot Injector - BL .020 for NG - 226758
.013 for LPG - 226759
- #8 x 1/2" sheet metal screw
- Label A - to be completed and applied to the lower door hinge.
- Label B - apply to the stove's Rating Plate
- Small valve label - apply to valve body
- Instructions

Fuel Conversion Procedure

1. Turn off gas supply to stove.
2. Open the door and release the glass frame latches to remove the glass frame and open the firebox. Tilt the glass frame forward and lift it out of the stove. See fig. 2.1, page 5.
3. Open the Controls compartment under the firebox. Loosen the Air Shutter wing nut located below the firebox floor and push the stem back far as it will travel. See fig. 7.1.
4. Remove the Burner: Lift the front of the burner base to disengage it from the support brackets and pull it forward off of the burner injector. Then tilt it side-to-side and pull it out through the door opening. Fig. 7.2.
5. Change the Burner Injector.
See fig. 7.3. Using a 1/2" open end wrench or deep-well socket, remove the burner injector from the brass elbow and replace it with the injector supplied in the conversion kit.

CAUTION: Do NOT over tighten the Burner Injector. Over tightening can damage the brass elbow and cause a gas leak!

6. PROPANE ONLY: Install the 1/2" Air Shutter Lock Screw (Fig. 7.3) provided in the LP Conversion Kit. The screw automatically sets the new, minimal shutter opening.
7. Change the Pilot Injector, Fig 7.3.
 - Use a 1/4" socket driver to remove the sheet metal screws and pilot shield from the pilot assembly. You may wish to remove the rear burner skirt for better access.
 - Use the 7/16" wrench to remove the pilot head base.
 - Remove the pilot injector from pilot base and replace with one in fuel conversion kit. Replace the pilot head and orient the hood to project flame to the Flame Sensor and burner carry-over ports. Be sure to orient the hood to project flame to the Flame Sensor and the burner carry-over ports.
 - Retighten the pilot base nut and replace the pilot shield and rear skirt.
8. Baffle Conversion - PROPANE ONLY:
 - Remove two, 10 mm nuts to detach and drop the Exhaust Baffle. You do not need to remove it from the firebox. See Fig. 7.4.
 - Loosen two, 10 mm nuts on the Upper Baffle, (Figs. 7.4 and 7.4a), enough to break both end wings off at the perforations. Retighten the two nuts.
 - Replace the Lower Baffle.

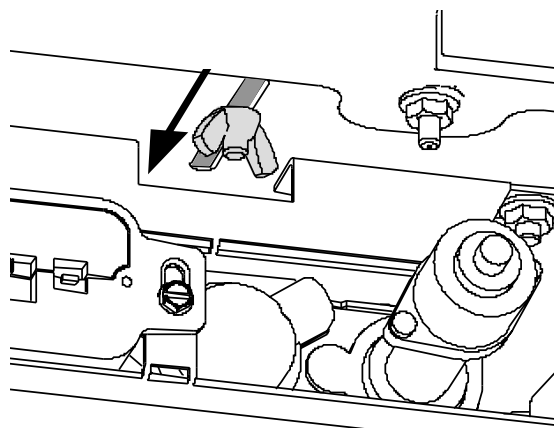

Figure 7.1.
Push Air Shutter stem FULLY back to disengage burner from injector.

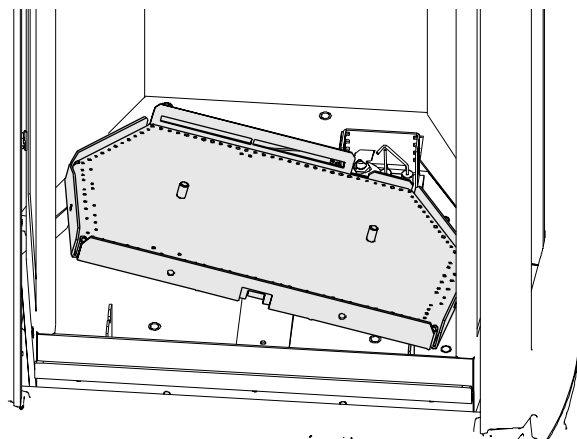
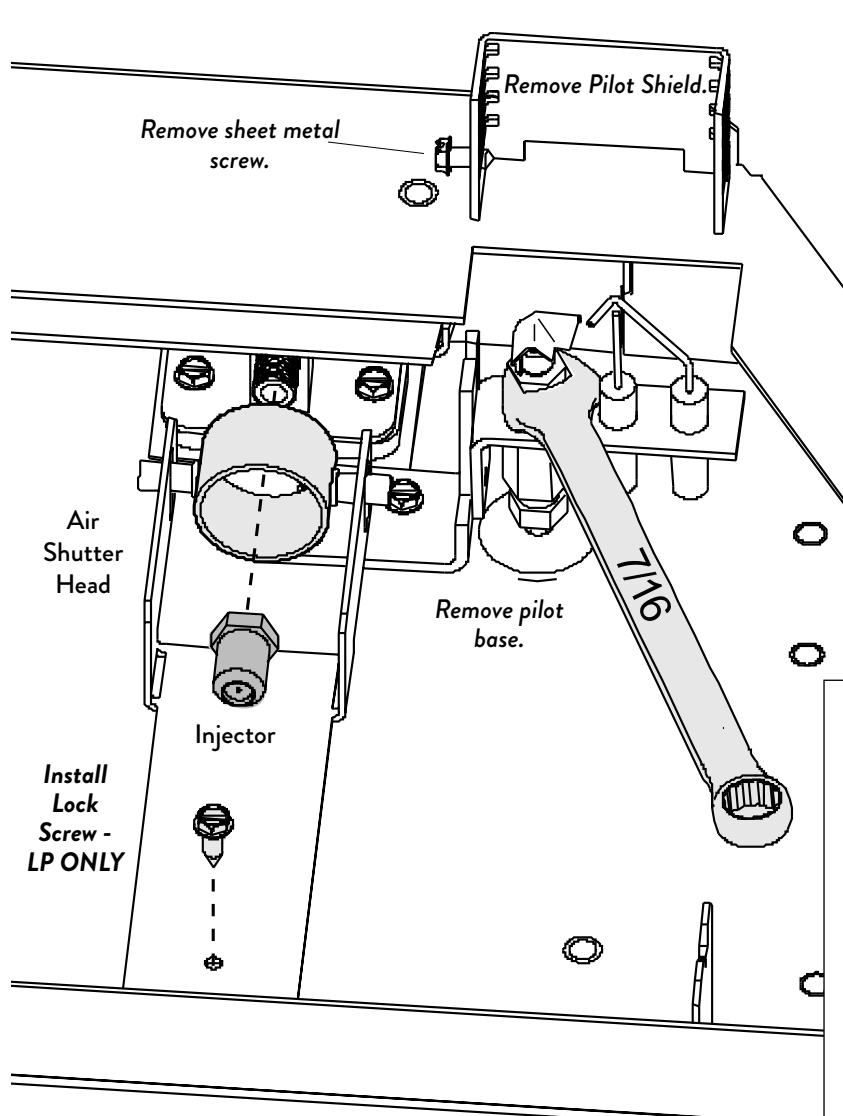

Figure 7.2. Remove Burner.



INSTALLER NOTE:
Pilot Shield is removed for PROPANE in a Minimum Vent Run.
 For taller vent configurations, or where high winds are present, the shield can remain installed if nuisance outages are experienced.
 Keep the Pilot Shield for potential future replacement.

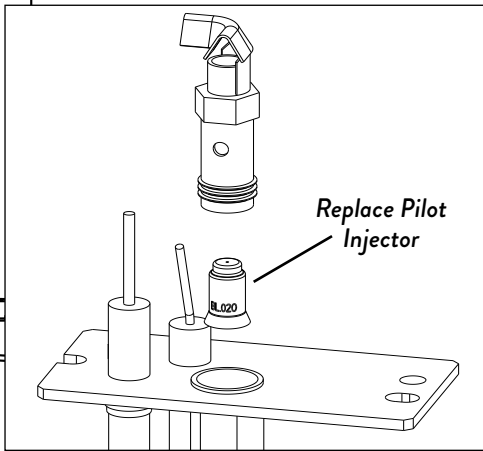

Figure 7.3.
Injector and Pilot conversion. The LP shutter lock screw sets the minimum shutter opening for propane.

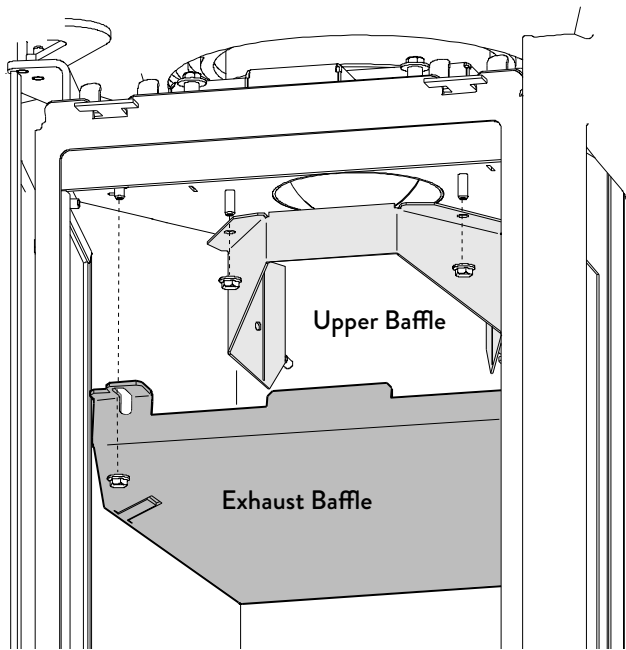

Figure 7.4. Upper Baffle, LP conversion.

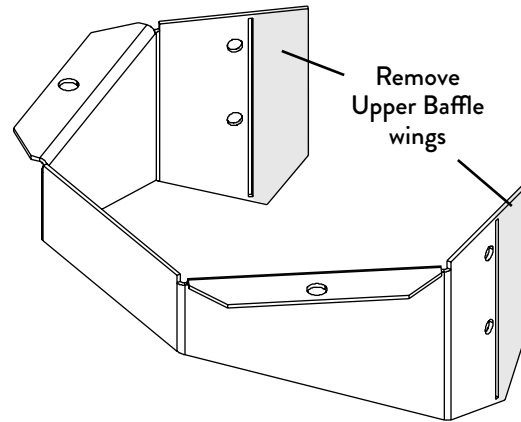

Figure 7.4a. Break off the Upper Baffle wings, LP conversion.

9. **Replace the Burner.** Tilt the burner assembly downward to engage the venturi tube with air shutter assembly. **BE CERTAIN THE BURNER IS LEVEL AND SECURELY ENGAGED WITH THE FRONT SUPPORTS ON THE FIREBOX FLOOR.**

10. **Regulator Motor Replacement**

Access the IFC module.

- Pull the Rating Plates out from the control cabinet, fig. 7.5.
- Remove the #8 sheet metal screws from each side of the control cabinet as in fig. 7.6. Carefully extend the wire harnesses to allow the IFC module to hang from the opening in the cabinet floor.

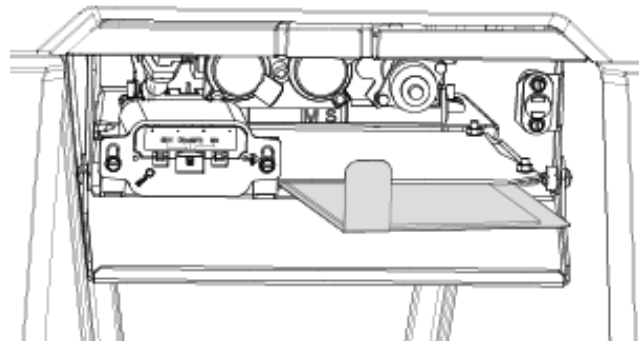

Figure 7.5. Pull rating plates out of the way.

11. **Regulator Conversion. Fig. 7.8.**

- Disconnect the Regulator motor wire harness lead from module Terminal "M", fig. 7.7
- Using a Torx T-20 screwdriver, remove the mounting screws from the original regulator and remove that assembly and leads from the gas valve.
- Install the conversion regulator motor using the new components included from that kit.
- Connect the motor leads to Terminal "M" on the IFC. See Figs. 7.7 - 7.8.

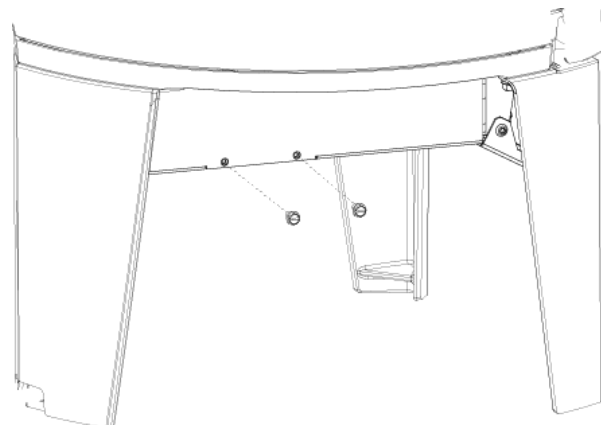

Figure 7.6. Remove IFC module bracket screws.

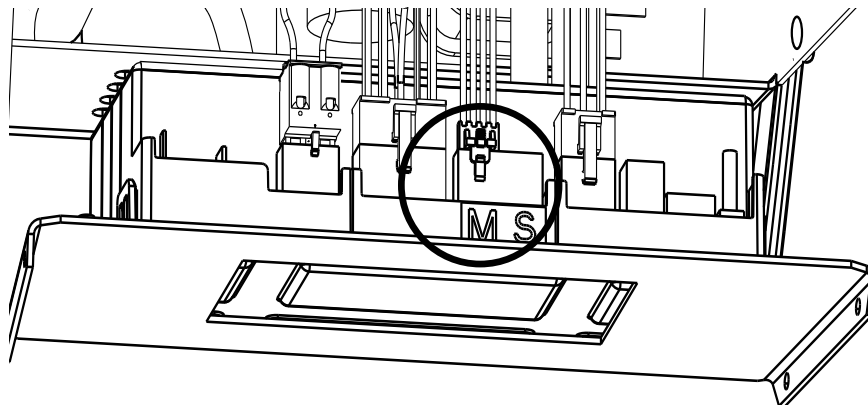

Figure 7.7.
Regulator motor connection terminal "M".

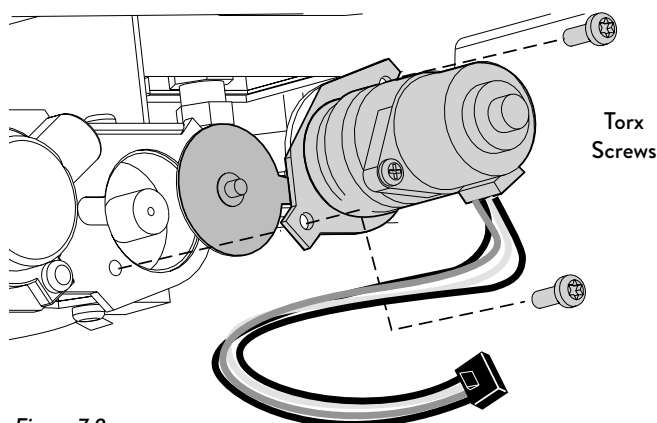

Figure 7.8.
Regulator motor removal and installation.

- Replace the IFC module within the controls cabinet and secure the mount bracket to the cabinet using the original sheet metal screws.

CAUTION: TAKE CARE TO AVOID CRIMPING WIRE LEADS DURING REASSEMBLY.

12. Apply the identification labels to the stove where they can be seen by a service person.

- **Label A:** apply to the Lower Door Hinge. Fig. 7.9.
- **Label B:** apply to the designated field on the stove rating plate stored under the gas valve in the Control Compartment.
- **Small Conversion Label:** apply to valve.

13. Reassemble the stove and apply gas to the system.

14. **Leak Check:** Check for leaks using a soapy water solution or digital gas detector. **NEVER USE OPEN FLAME TO CHECK FOR GAS LEAKS. AVOID WETTING THE IFC UNIT WHEN CONDUCTING LEAK CHECK.**

15. **Confirm correct gas pressure.** Use a manometer to check pressures as specified under Section 9, Gas Pressure (page 19).

Apply Label
"A" to lower
door hinge.

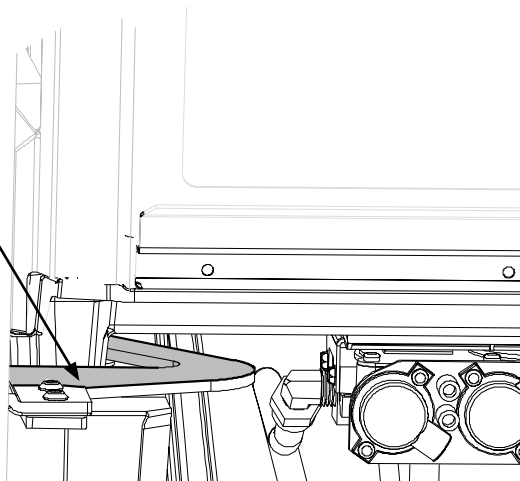

Figure 7.9.
Conversion label "A" location.

Fuel Conversion, cont'd.**16. NATURAL GAS ONLY: Adjust the Air Shutter. Fig. 7.10**

The factory setting for NG is 1/16" open. Adjustment may be necessary to provide the best flame picture depending upon the specific vent configuration.

- Start with the shutter set open to 1/16".
- Push the shutter stem back (to the rear) to restrict air.
- Pull the shutter stem forward (toward yourself) to open the shutter and add oxygen to the fuel mix.

With some experimentation, you will find the shutter position that works best for that particular installation.

- Run the stove at least 15 minutes to let the burner settle-in before making further adjustments in very small increments (1/16" - 1/8")

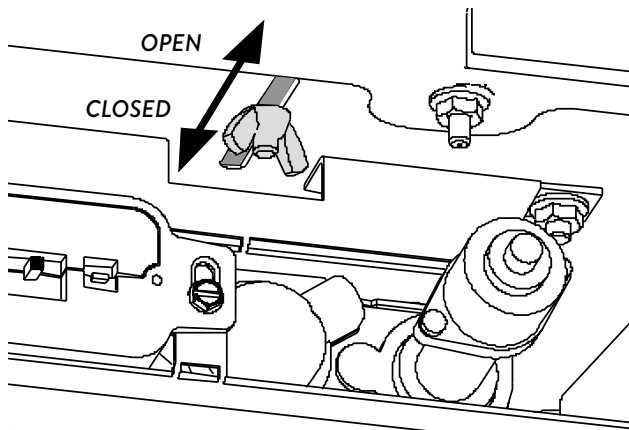

Figure 7.10.
Air shutter adjustment.

8. Gas Supply Connection

- Route the gas supply line to the flex line behind the Utility Cover at the rear leg.
- The gas supply line should be 3/8" npt with a 1/2" diameter supply, or the appropriate size to provide sufficient gas pressure to the valve regardless of the input setting.
- The use of Flexible Gas Appliance Connectors is acceptable in many areas in the U.S. However, Canadian methods vary depending on local code.
- **ALL INSTALLATIONS MUST COMPLY WITH LOCAL CODE OR IN THE ABSENCE OF LOCAL CODE, MUST COMPLY WITH THE MOST RECENT EDITION OF THE NATIONAL FUEL GAS CODE ANSI Z223.1/ NFPA 54 OR CAN-B149.**
- All codes require a gas shut-off valve (gas cock) and union, to be installed in the supply line, and in the same room as the appliance. This allows for the disconnection of the stove for servicing and maintenance. See fig. 8.1.

A T-HANDLE GAS COCK IS REQUIRED IN MASSACHUSETTS TO COMPLY WITH CODE 248CMR.

- Secure all joints tightly using appropriate tools and sealing compounds. **For propane units be sure to use compounds that are propane resistant.** Turn on gas supply and test for gas leaks at all joints.

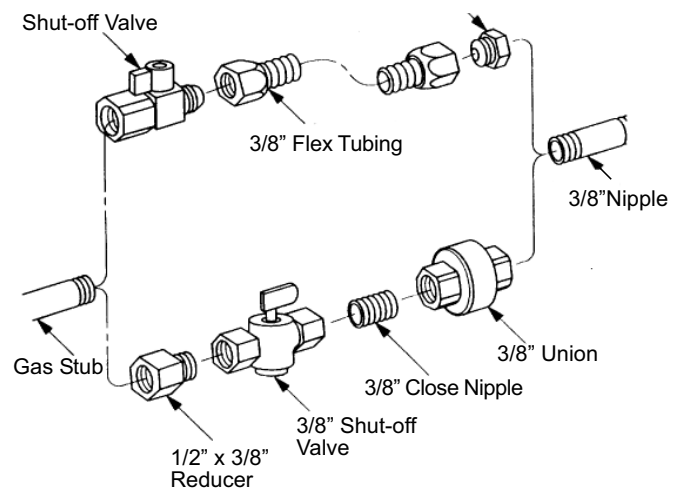

Figure 8.1. Gas supply line connection alternatives.

9. Gas Pressure

Correct gas pressure is essential for efficient and safe operation of the GF 160 DV IPI gas stove. It is important that the correct pressure is established at the time of the installation. Proper gas pressure provides a consistent flow of gas to the appliance and is instrumental in checking for gas leaks.

Pressure Test: Attach a manometer to the appropriate test point on the valve. See fig. 9.1.

The gauge connections are located on the front of the valve. Connections are identified by:

A - for Manifold Pressure (the amount of gas that is coming out of the valve to the burner.)

B - for Inlet or Supply Pressure (the amount of gas coming to the valve.)

ALWAYS TEST PRESSURES WITH VALVE CONTROL KNOB SET ON HIGH.

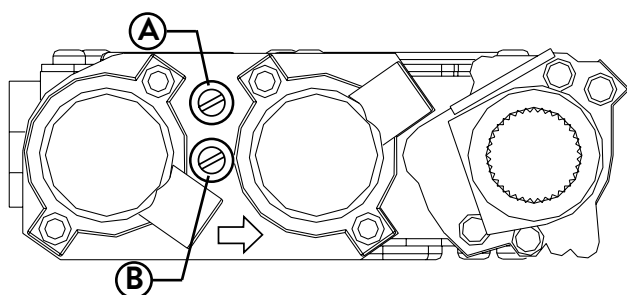

Figure 9.1. Pressure test points.

INLET GAS PRESSURES (inches water column)

| | MIN | MAX |
|-------------|------|------|
| NATURAL GAS | 5.0 | 7.0 |
| PROPANE | 11.0 | 14.0 |

The appliance and its appliance main gas valve must be disconnected from the gas supply piping system during any pressure testing on that system at test pressures in excess of 1/2 psig (3.5 kPa).

The appliance must be isolated from the gas supply line by closing its individual manual gas shut-off valve (gas cock) during any pressure testing of the gas supply piping system that is equal to or less than 1/2 psig (3.5 kPa).

MANIFOLD PRESSURES (inches water column)

| | MIN | MAX |
|-------------|-----|------|
| NATURAL GAS | 1.6 | 3.5 |
| PROPANE | 6.4 | 10.0 |

10. High Altitude Adjustment

The decreased atmospheric pressure of higher altitudes affects heat value of gaseous fuels. Most gas suppliers derate the gas intended for use at elevations above 2000 feet. Check with your gas supplier before performing derate adjustment to the burner. If the gas supplier does not derate fuels, install High Altitude Adjustment Kit 158059 for Propane and Kit 158060 for Natural gas.

U.S & Canada per ANSI Z21.88-2019 • CSA 2.33-2019, CAN/CGA 2.17

Orifice Sizes for 610-1370 meters (2000-4500 ft.):

Natural Gas: 2.30 mm

Propane: 1.40 mm

See data on the stove rating plate for additional information. At higher altitudes, consult the local gas distributor or the authority having jurisdiction for proper rating methods. If the installer must convert the unit to adjust for varying altitudes, the information label must be filled out and applied to the appliance at the time of the conversion.

Derating Procedure

- Follow the steps for Burner Injector replacement in the Fuel Conversion procedure on pages 14-15. Use the injectors supplied with the adjustment kit. Detailed instructions are also included in the kit.
- Conduct gas leak and gas pressure tests as detailed in the preceding section of this manual.
- Conduct system check and flame picture adjustments as specified on pages 23-24.

INSTALLER: Fill out the appropriate information and apply the high altitude conversion label provided to the rating plate on the appliance. See fig. 10.1.

This appliance has been converted for use at an altitude of _____ .
 Orifice Size: _____ Manifold Press. _____
 Input Btu/Hr. _____ Fuel Type _____
 Date: ___/___/___ Converted by: _____
 Cet appareil a été converti au _____ Injecteur _____
 Pression à la tubulure d'alimentation _____ Débit calorifique _____

Figure 10.1. High Altitude Conversion Label.

11. Accessories

Firebox Panel Kit

Skamol Firebox Liner Kit 158046

Black Reflective Glass Panel Kit 157965

Skamol Panel Contents:

- Rear Panel226029
- Side Panels, 2226030

Tools:

- Flat head screw driver

Reflective Black Glass Contents:

- Rear Panel226073
- Left Side Panel.....226075
- Right Side Panel.....226074
- Cotton Gloves, 2

**INSTALL FUEL OR HIGH ALTITUDE
CONVERSION KITS BEFORE INSTALLING
PANEL KITS.**

**THE PANELS ARE FRAGILE.
SUPPORT EACH WITH BOTH HANDS.**

**HANDLE THE GLASS PANELS WITH THE COTTON
GLOVES PROVIDED TO MINIMIZE FINGERPRINTS.
SKIN OILS ARE DIFFICULT TO REMOVE FROM THE
GLASS SURFACE.**

This procedure applies to both kits.

**ORIENT GLASS PANELS WITH THE
SMOOTH SIDE FACING OUT.**

1. Set the Rear Panel, bottom first, behind the pilot assembly shield and resting on the rear shelf. When installed, the two side panels will hold the rear in place.
2. The side panels rest on the shelves at each side of the burner. Each panel is secured by a single Retainer Tab located within the upper corner of the firebox ceiling. Set a panel in place against the firebox wall and use a flat head screwdriver to pry the retainer tab down just enough to hold the panel snug in place.
3. Repeat with the other side panel.

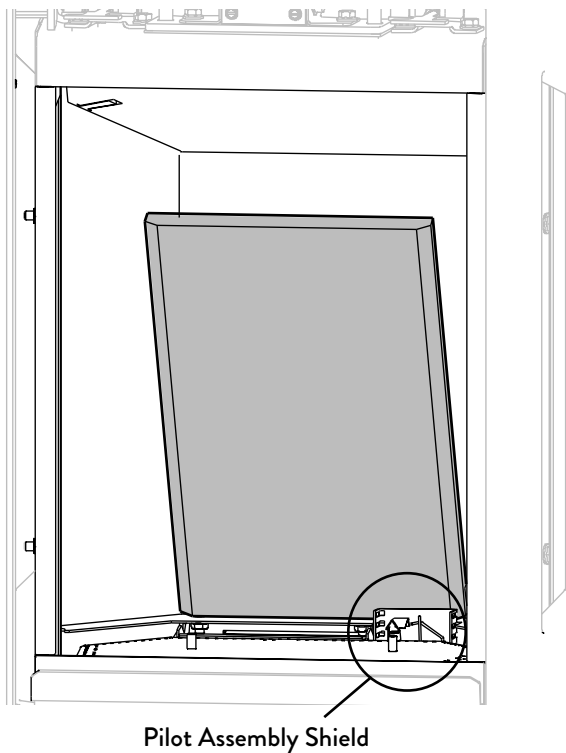

Figure 11.1. Install Rear Panel.

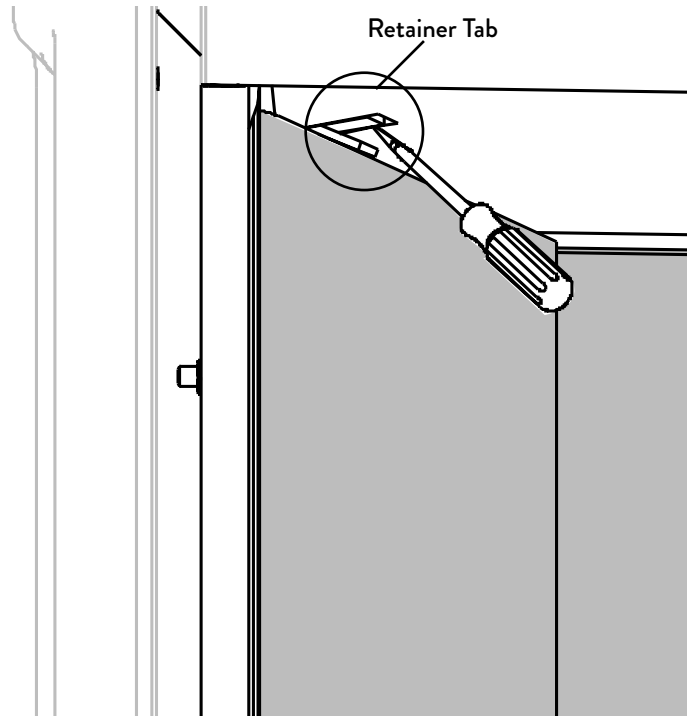

Figure 11.2. Install Side panels.

12. Install Burner Media

Do not install burner media until after all other accessory installations or component adjustments have been completed.

Log Set 158045

NOTE: LOG COMPONENTS ARE FRAGILE. WEAR SAFETY GLOVES AND HANDLE LOGS WITH CARE.

Contents:

| | | |
|----|--------------------|--------|
| #1 | Base Log..... | 226264 |
| #2 | Left Log..... | 226265 |
| #3 | Right Log..... | 226266 |
| | Ember Stones | 6 oz. |

Inspect the log parts and report any damage to your dealer. **DO NOT INSTALL DAMAGED LOGS.**

- Base Log:** Engage the holes in the underside of Base Log #1 with the two pins on the burner base.
- Right Log:** Rest the end of the Right Log #2 in the small pocket on the Base Log as shown in fig. 12.2. Rest the upper end of the log against the back corner of the firebox as shown in fig. 12.1.
- Left Log:** Engage the hole in the charred end of the Left Log #3 with the Base Log pin and lean it up against the back corner of the firebox. See figs. 12.1 and 12.2.
- If desired, spread the Ember Stones over the Burner Base in a thin layer. **DO NOT COVER GAS PORTING HOLES ON THE SIDES OR FRONT OF THE BURNER. PLACE STONES OVER THE REAR PORTS ONLY AND UP TO THE REAR FLANGE OF THE BURNER.**
KEEP EMBER STONES AWAY FROM THE PILOT CARRY-OVER AREA AND BURNER PERIMETER.

The Rock Wool included in the Miscellaneous Kit is intended as an enhancement to replicate glowing embers. Use a toothbrush or tweezers to sparingly apply small pinches of fibers over the front of the burner base after the log components have been installed. The ample supply of rock wool is provided for ease of handling and application purposes only. **DO NOT USE THE ENTIRE QUANTITY OF ROCK WOOL.** Use no more than 1/4 of the material supplied.

Please be aware that sooting may occur with Propane fuel under minimum vent configurations. Should soot develop, use a soft brush to clean the log and remove some or all of the rock wool from the burner.

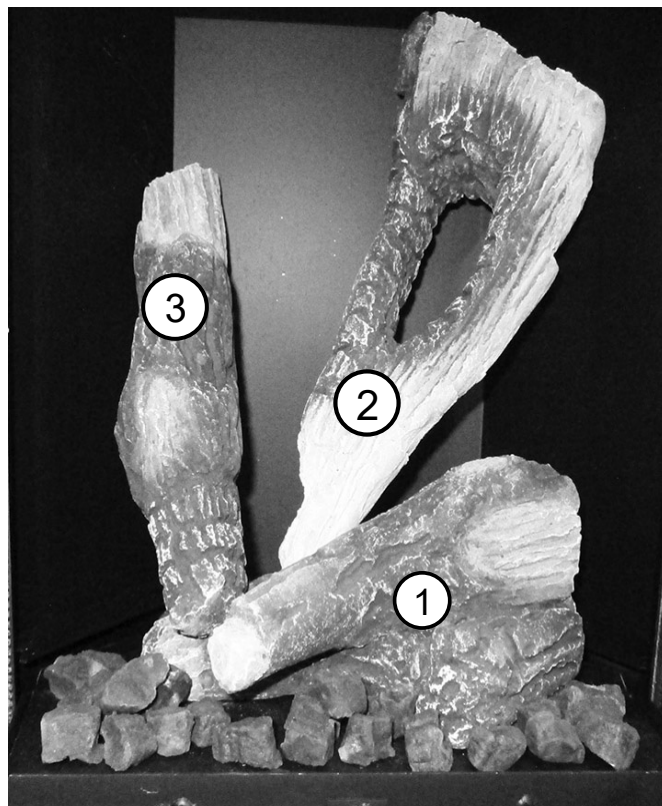

Figure 12.1. Fully assembled log set.

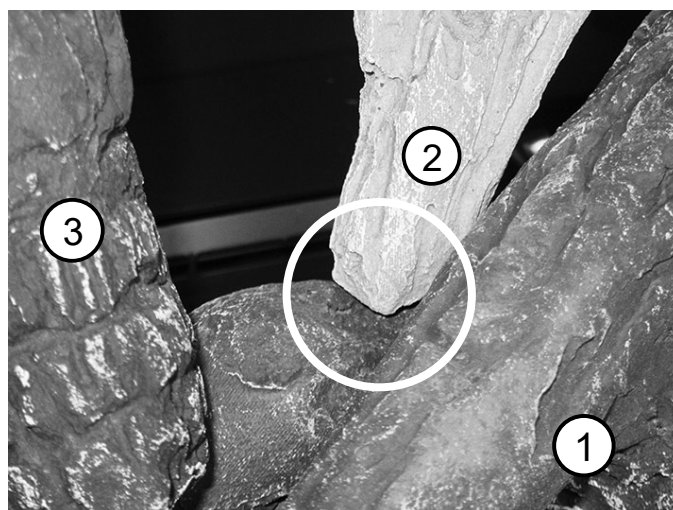

Figure 12.2. Rest the end of the Right Log in the small pocket on the Base Log.

River Rock Set 158055

- Orient the rock assembly to engage with the burner pins as shown fig. 12.3a.

NOTE THE DIFFERENCE BETWEEN THE CORRECT AND INCORRECT ORIENTATION (fig. 12.3b).

INCORRECT ROCK SET ORIENTATION WILL RESULT IN POOR PERFORMANCE.



Figure 12.3a River Rock orientation - **CORRECT**.



Figure 12.3b. *Incorrect River Rock orientation.*

Tumbled Stones 158054

- Apply the stones in a single layer across the burner surface. The stones may cover porting, but take care that flat stones do not completely block gas flow through the ports. in a single layer. Also, **DO NOT OBSTRUCT THE AIR SPACE BETWEEN THE BURNER PERIMETER AND THE BURNER SKIRT.** See fig. 12.4.



Figure 12.4. *Tumbled Stone layout.*

Clear/White Fire Glass 156815

Black Fire Glass 157342

- Do not use more than the four pounds (in two, 2 lb. bags) of glass media provided. For best results, evenly spread the contents of the bag over the entire burner plate, mounding a crown toward the center.
- **DO NOT COVER THE AREA IMMEDIATELY IN FRONT OF THE PILOT ASSEMBLY.** The carry-over ports directly in front of the pilot assembly must remain clear to ensure proper pilot ignition. See fig. 12.5.
- **NOTE:** Glass may discolor over time. Soak glass in a detergent bath to bring back the original crystalline finish.



Figure 12.5. *Fire Glass layout.*

13. System Check

- PURGING THE GAS LINE:** When lighting the appliance for the first time, it will take a few moments to clear the gas line of air. Once this purge is complete, the appliance will operate as described in the lighting instructions. From a cold start, it may be helpful to let the pilot light burn in mode for 10 - 15 minutes to establish positive draft, before turning the burner on. See the procedure on the inside back cover of this manual. Subsequent burner starts will not require purging the gas line unless the supply line is shut off.
- PILOT FLAME:** You can monitor the pilot flame located behind the burner at the rear of the firebox. The pilot flame should be steady - not lifting or floating. The flame should be blue in color around the pilot hood, with traces of yellow toward the outer edges. Fig. 13.1.
The pilot flame should engulf the top 1/8" of the flame sensor. The pilot flame should project from the pilot hood port toward the burner carry-over ports. Adjust the pilot flame using the adjustment screw to the left of the valve regulator. See fig. 13.2.
- See Flame Appearance / Air Shutter for air shutter settings and adjustments. Note: The more offsets there are in the vent system, the greater the need for an air shutter adjustment.

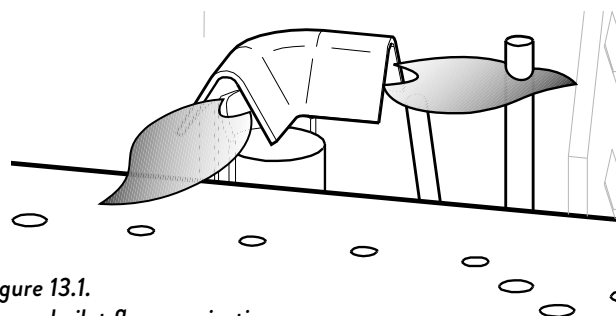

Figure 13.1.
Normal pilot flame projection.

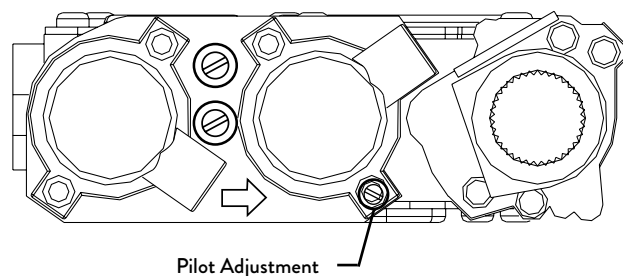
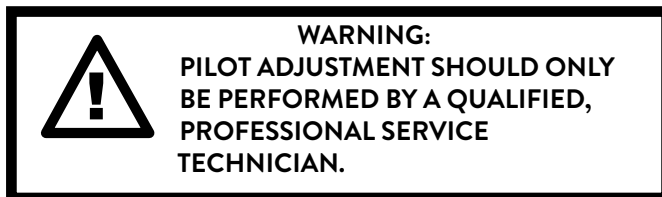

Figure 13.2. Pilot flame regulation.

INITIAL FIRING PROCESS - Heat-curing the Stove Paint

This appliance has been painted with the highest quality coating used in the hearth industry. Manufacturers have selected this product because it has been proven durable, colorfast, and beautiful at temperatures up to 1200°F/650°C. Although the paint has been air-dried at the factory, it must be heat-cured in order to maximize its coating properties and durability. This process occurs during initial firing of the appliance and will generate odor and some visible smoke.

We recommend you do the following BEFORE operating the appliance for the first time:

- Ventilate:** Open doors and windows and use a fan to circulate fresh air throughout the room.
- Vacate:** The fumes are non-toxic, but can be uncomfortable for babies, small children, pregnant women, elderly, pets, or anyone having breathing difficulties.

Gas Appliance Curing Process

- After the installer has confirmed proper burner function at all heat levels, the homeowner should operate the appliance at a low setting for several hours, followed by several hours operation at a high setting.
- Off-gassing by paint and log set ceramic material may leave a white, powdery deposit on the inside surface of the glass panel. **This residue must be removed using a non-abrasive hearth gas appliance glass cleaner or warm water to prevent permanent etching of the glass.**

DO NOT USE AMMONIA-BASED CLEANERS. DO NOT CLEAN HOT GLASS.

See OPERATION sections, pages 25-30, for detailed, day-to-day operating procedures.

14. Flame Appearance / Air Shutter Adjustment

The GF 160 DV IPI gas stove is shipped from the factory equipped to burn Natural gas and the air inlet shutter has been set to provide optimal combustion efficiency under a variety of venting configurations. The air shutter may be adjusted, however, to accommodate the conditions of your individual installation and to provide the desired flame picture. Other installation-related variables can also affect the flame picture:

Too large an air setting - the appliance will generate a flame that is blue and transparent, or an “anemic” flame.

Too small an air setting - the appliance will generate very long yellow flames resulting in black soot deposits on the logs, on the inside walls of the appliance, and potentially on the exterior termination cap. Sooting is caused by incomplete combustion in the flames and/ or insufficient combustion air entering the air shutter opening.

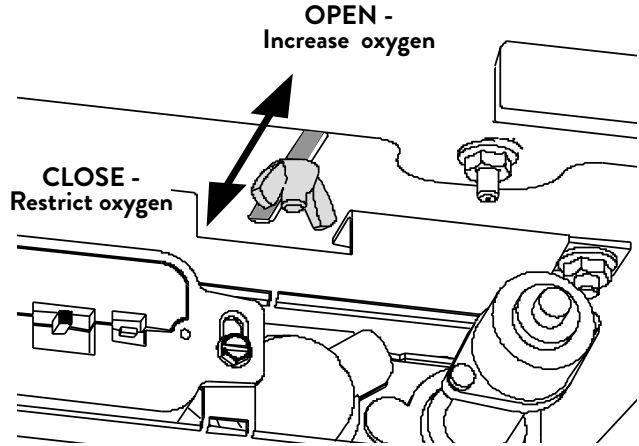

Figure 14.1.
Pull the shutter forward to increase primary air.
Push it back to restrict air.

To adjust the air shutter:

1. Open the front door to access the air shutter. Open the Controls Access Door and loosen the wing nut shown in fig. 14.1. Slide the wing nut stud forward toward yourself to open the air shutter and back to provide less air. Before making any adjustments, start at the mid-point of the total range of adjustment.
2. Allow the stove to burn for 20-30 minutes on the HIGH setting, observing the flame continuously. If the flame appears weak, slow, or sooty, increase the air shutter opening in 1/16" - 1/8" increments until the desired flame picture is achieved. Allow the flames a few minutes to “settle-in” after each adjustment.
3. Tighten the wing nut to secure the shutter at the desired setting.

For other burner media reference flame patterns, see the Appendix, page 41.



Figure 14.2. Log Set burner flame picture.

15. Operation

Important Notes

1. For the first several hours of operation, it is common to detect some odor as the metal and manufacturing materials cure under heat. This condition is temporary and can be alleviated by allowing plenty of fresh air to circulate through the area.
2. Condensation may develop on the glass upon each lighting of the appliance. This “fog” will disappear as the glass heats.
3. **IMPORTANT:** It will be necessary to clean the glass after the first few fires. A white powdery residue will be evident which results from the burner media curing. *Use a non-abrasive hearth gas appliance glass cleaner and warm water.*

IF THE GLASS IS NOT CLEANED, THIS RESIDUE CAN CAUSE THE GLASS TO BECOME PERMANENTLY ETCHED.

DO NOT USE AMMONIA-BASED CLEANERS.

4. Keep the control compartments and area under the appliance free of dust. Always keep the appliance area clear and free from combustible materials, gasoline and other flammable liquids.
5. This appliance can be operated with a continuously burning pilot flame. Exercise caution when using household products containing combustible vapors.
6. **CAUTION: DO NOT OPERATE THIS APPLIANCE WITH ANY OF THE GLASS PANELS REMOVED, CRACKED OR BROKEN. REPLACEMENT OF THE GLASS SHOULD BE DONE ONLY BY A LICENSED OR QUALIFIED SERVICE PERSON. USE ONLY REPLACEMENT GLASS PROVIDED BY YOUR AUTHORIZED JØTUL DEALER. NEVER SUBSTITUTE ANY OTHER TYPE OF GLASS.**
REMOVE GLASS ONLY FOR ROUTINE MAINTENANCE.
ALWAYS HANDLE GLASS CAREFULLY.

WARNING:

READ AND UNDERSTAND ALL OPERATING INSTRUCTIONS BEFORE ATTEMPTING TO OPERATE THIS APPLIANCE. DO NOT ALLOW ANYONE TO OPERATE THIS APPLIANCE WHO HAS NOT READ AND UNDERSTOOD THESE INSTRUCTIONS. KEEP THE REMOTE CONTROL TRANSMITTER WHERE CHILDREN CANNOT REACH IT.

WARNING:

SEVERE INJURY. THIS APPLIANCE CAN BE SET TO OPERATE THERMOSTATICALLY. BE AWARE THAT THE APPLIANCE MAY BE VERY HOT EVEN WHEN THE BURNER IS NOT APPARENTLY OPERATING. KEEP CHILDREN AWAY FROM THE APPLIANCE.

WARNING:

OBSERVE CAUTION NEAR THE GLASS PANEL. THE GLASS MAY SHATTER IF STRUCK BY AN OBJECT. ALWAYS HANDLE THE GLASS PANEL WITH CARE.

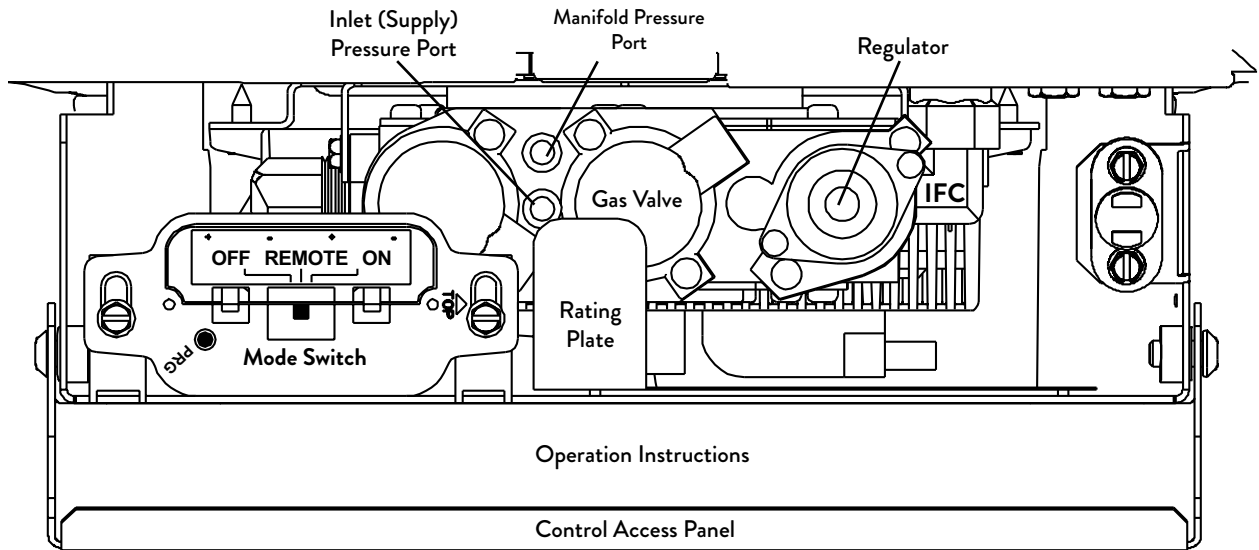

Figure 15.1. GF 160 DV IPI Controls Compartment.

Burner Operation

Familiarize yourself with the controls of the GF 160 DV IPI and be sure that anyone else using the appliance is also familiar with the controls and operation procedures. Always follow the Lighting Instructions on the inside back cover of this manual and also located on the inside the Controls Access Panel.

This appliance is equipped with an ignition device that lights the pilot automatically. **Do not try to light the pilot by hand.**

1. Set the Mode Switch to **OFF**. See fig. 15.1.
2. Confirm the stove is connected to 120VAC house current.
3. **Mode Switch Function:**
 - **ON / OFF** - Use for manual control of the burner. When set to ON, the pilot will light, followed by burner ignition.
 - **REMOTE** - Set for handheld transmitter control or remote thermostatic control.

Proflame 2 Remote Control

Features Overview

The Proflame 2 Integrated Fireplace Control (IFC) incorporates electronic remote control of the Jøtul GF 160 DV IPI features. It is configured to control the on/off operation both manually and thermostatically, with standard and “Smart” thermostat features. It will also control flame modulation and accent lighting functions.

The burner utilizes an IPI system (Intermittent Pilot Ignition) and may also be switched to keep the pilot lit continuously if desired (CPI - Continuous Pilot Ignition).

CPI NOTE: This appliance is equipped to automatically extinguish the pilot light after 7 days if there is no call for heat during that period. The pilot will convert to IPI mode and re-ignite at the next call for heat.

Power is provided to the IFC by 120V house current. In the event of a power failure, burner operation is backed-up by a 6V battery pack (four, 1.5v AA).

Remote Control Transmitter

The remote transmitter has all controls available on its face for reliable, ease of use. It gives room temperature readout, set temperature readout, all function abilities as well as childproof lockout and low battery indicator. Icons appear on the screen indicating which mode of operation you are controlling. The four button controls are easy to learn and simple to operate. The transmitter is powered by three (3), 1.5V AAA batteries.

Remote Control Receiver

The receiver is integrated with the IFC board which is located within the valve compartment.

Integrated Fireplace Control (IFC)

The IFC is the electrical heart of the system. It provides power to all components and converts to 6.5v DC in the event of power failure. The IFC also sends power to the the accent light, however, when no line power is available, that feature will not function. The battery back-up only allows continued remote control of burner functions.

Sit 886 Modulating Valve

This valve has the ability to be stepped down in six increments between high and low. It can be done manually or by setting the remote control to the Smart thermostat modulation mode. Automatic modulation means that as the room temperature approaches the limit set for shut down, the valve gradually decreases or “steps-down” the fire intensity. Conversely, as room temperature cools, the valve gradually increases flame intensity. The overall result is more comfortable, even heating that minimizes temperature peaks and valleys.

Pilot Assembly

The pilot assembly consists of a pilot hood, electrode, and a flame sensor. The electrode sends a spark to the pilot hood which ignites the gas. The sensor is then engulfed by the pilot flame, flame rectification occurs and the burner ignites when there is a call for heat.

Intermittent Pilot Flame Rectification Process

When there is a call for heat, the pilot will automatically make four attempts to light the burner before locking out.

On the first attempt, the pilot will spark for up to sixty (60) seconds. If rectification occurs within that time, the burner will light off. If rectification does not occur, the pilot will extinguish.

If the main burner ignites and rectification is lost, the system will extinguish the burner and immediately ignite the pilot and relight the burner. The system will attempt to light the main burner three (3) more times. On the fourth attempt, the system will again light the pilot and then sit idle with only the pilot burning for sixty (60) seconds in order to establish draft to support combustion air flow.

If rectification still does not occur with the main burner lit, the system will “lock out”.

A lock-out condition is cleared by cancelling the call for heat; i.e. switching the burner off, or adjusting the thermostat.

INSTALLER / OPERATOR NOTE

Under certain conditions wherein draft is unstable or weak, it is advisable to run the system in Continuous Pilot mode (CPI). Warm weather, extreme cold weather, a long vent run, or high wind conditions are all contributing factors that can interfere with IPI functionality. A continuously running pilot can generate sufficient heat to help establish and maintain the draft strength required for rectification to occur.

ATTENTION:

- SHUT “OFF” MAIN GAS SUPPLY PRIOR TO REMOVING OR REPLACING BATTERIES.
- IN CASE OF REMOTE CONTROL MALFUNCTION, TURN OFF THE IFC DEVICE USING THE MAIN “ON/OFF” SWITCH.
- FOR INSTALLATION/MAINTENANCE, TURN “OFF” THE IFC BY DISCONNECTING THE MAIN POWER SUPPLY PLUG.

Remote Control Functions

Pilot Mode

Set the Mode switch to **ON** to light the pilot. The burner will ignite and remain on until manually switched **OFF**.

NOTE: This appliance is equipped with a timed valve that will automatically shut off the pilot light after seven (7) days. Follow the Lighting Instructions inside the control compartment door to relight the pilot.

Burner Control

Set the stove burner switch to **REMOTE** for Proflame 2 remote control.

OFF - Turns off both remote and manual burner functionality. Switch to **OFF** when the stove will not be used for an extended period of time.

Remote Transmitter

The Transmitter features a simple button layout and informative display screen. See fig. 15.2.

LCD DISPLAY - graphically indicates temperature settings and status of the Thermostat, Burner, and Accent Lamp.

ON / OFF Key - controls Burner and Lamp functions.

THERMOSTAT Key - Used to set either Manual or Thermostatic Control and index through thermostatic functions.

UP / DOWN Arrow Key - Selects thermostat temperature range and flame height.

MODE Key - used to select the component to be controlled: CPI/IPI, Burner, Fan and Accent Lamp.

Initializing the System

1. Press the Controls Access Door to release its magnetic catch and swing the panel down. Switch the Mode to **REMOTE**. See fig. 15.1.
2. Install three AAA batteries into the Transmitter handset.
3. Press the **PRG** button on the Left front corner of the switch plate. The board will “beep” three times and a yellow LED will indicate a 10-second synchronization time limit.
4. Within 10-seconds, press the Transmitter **ON** button. The IFC will “beep” three or four times to indicate that it has acknowledged the transmitter command and sets to the particular code of that Transmitter.
5. After initialization, place the Mode switch in the **REMOTE** position. The hand-held transmitter can then be used to control the burner.

To return to full Manual functionality:

- Switch the Mode to **REMOTE**.
- Press the red button on the until it “beeps” three times. Within 10 seconds, press the button again until acknowledgement is signalled.

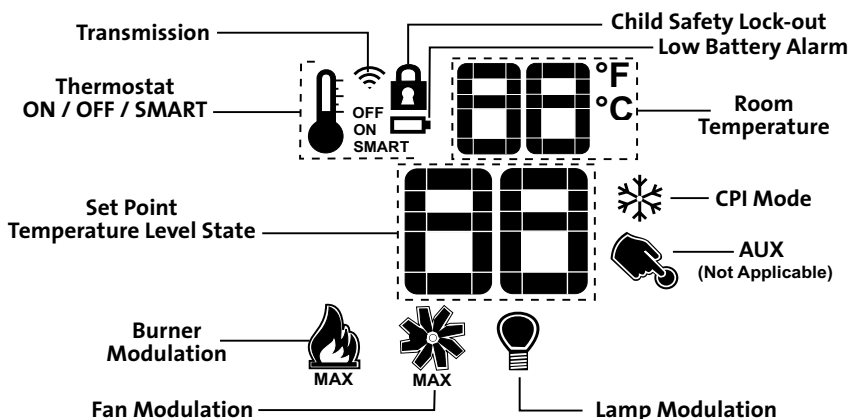

Remote transmitter function keys.

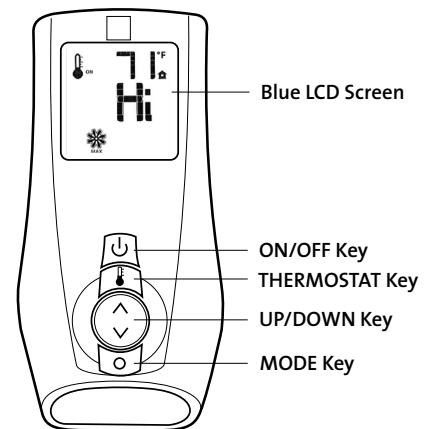

The supplied Wall Mount Bracket can be used for convenient transmitter storage.

Figure 15.2. Remote transmitter display data.

Remote Transmitter Controls

Temperature Indication Display

- With the transmitter in the OFF position, press the Thermostat Key and the Mode Key at the same time. The display screen will show the current room temperature cycling between Fahrenheit and Celsius indicators each time the keys are pressed simultaneously. Fig. 15.3.

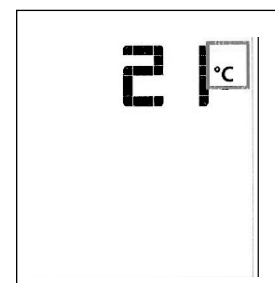
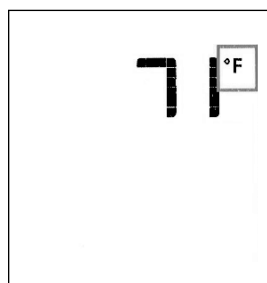

Fig. 15.3. Room temperature readings

Pilot Mode

- With the transmitter in the OFF position, press the transmitter Mode key - IPI is the default mode. Fig. 15.4. Press the Up arrow to index to the CPI icon and activate the Continuous Pilot Ignition mode. Fig. 15.5. Pressing the Down Arrow Key will return to Intermittent Pilot Ignition. A single “beep” will confirm reception of the command.

NOTE: Setting the stove Pilot Mode switch to IPI will disable remote IPI/CPI switching.

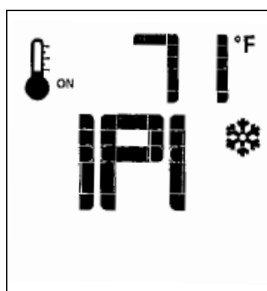

Fig. 15.4. IPI is the default position.

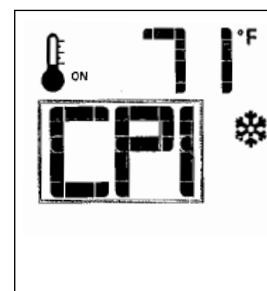

Fig. 15.5. CPI ON.

Turn on the Burner

- Press the ON/OFF Key on the Transmitter.

The display will show all the active icons. At the same time, the Receiver will activate the Pilot Ignitor. First the pilot will ignite, followed shortly by the burner. A single “beep” from the Receiver will confirm reception of the command.

Turn off the Burner

- Press the ON/OFF Key. The display will show only the room temperature and icon. At the same time, the Receiver will deactivate the call for heat and the burner will shut down. Fig. 15.7. A single “beep” from the Receiver will confirm reception of the command.

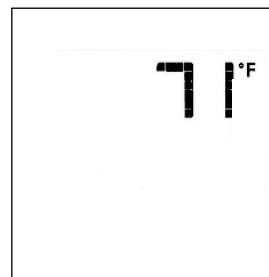

Fig. 15.6. Burner shut-down

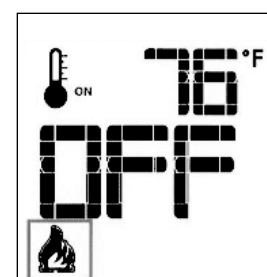

Fig. 15.7. Burner OFF.

Remote Burner Control

There are six flame levels available.

- With the system ON, and the burner flame level at maximum, press the Down Arrow Key once to reduce the flame height by one step. Each time the Down Key is pressed, the flame will step down until the burner is finally turned off. Fig. 15.8.
- The Up Arrow Key will increase the flame height each time it is pressed. If the Up Arrow Key is pressed while the system is on but the flame is off, the flame will come on in the High position as in figs. 15.8 - 15.10. A single “beep” will confirm reception of the command.

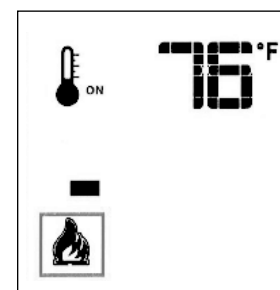

Fig. 15.8. Flame Level 1.

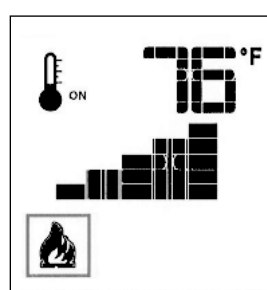

Fig. 15.9. Flame Level 5.

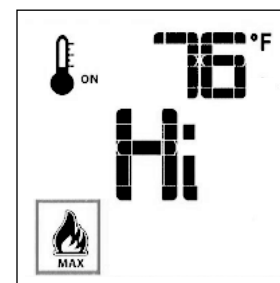

Fig. 15.10. Flame Level 6.

Room Thermostat (Transmitter Operation)

The Remote Control can operate as a room thermostat. The thermostat can be set to a desired temperature to control the comfort level in a room.

- To activate this function, press the Thermostat Key. The display will indicate that the room thermostat is “ON” and the current Set Temperature is now displayed. Fig. 15.11.
- To adjust the Set Temperature, press the Up or Down Arrow Keys until the desired Set Temperature is displayed. Fig. 15.12.

SMART Thermostat Function

This function adjusts the flame intensity according to the difference in the Set Point temperature and the actual room temperature. As the room temperature gets closer to the Set Point, the Smart Function will modulate flame intensity down.

- To activate this function, press the Thermostat Key until the word “SMART” appears to the right of the thermometer bulb icon. Fig. 15.13.
- To adjust the temperature, press the Up or Down Arrow Keys until the desired Set Temperature is displayed. Fig. 15.14.

Accent Lamp Control

- With the Remote ON, press the Mode Key to index to the Lamp icon. Figs. 15.15.
- Pressing the Up Arrow Key will turn the Lamp ON. Press the arrow keys to adjust the brightness. Fig. 15.16.
- Pressing the Down Arrow Key will turn the Lamp OFF.

Child Safety Lock

This function will lockout the Transmitter to prevent unsupervised operation.

- To activate the Lock, press the Mode key and UP Key at the same time. Fig. 15.17.
- To de-activate the Lock, press the Mode Key and UP Key at the same time.

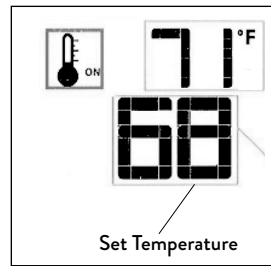

Fig. 15.11. Thermostat ON.

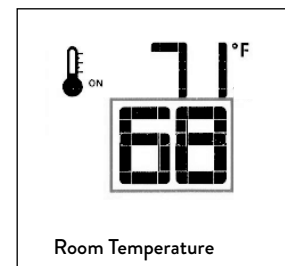

Fig. 15.12. Change Set Temperature.

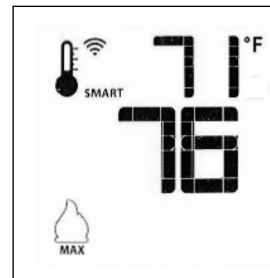

Fig. 15.13. Smart Mode

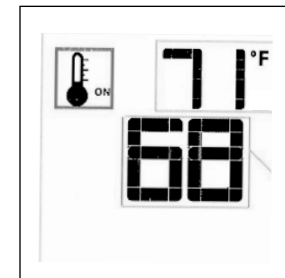

Fig. 15.14. Smart Set Temp.



Fig. 15.15. Lamp Control.

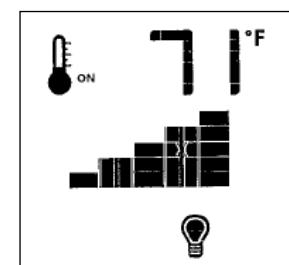

Fig. 15.16. Lamp ON.

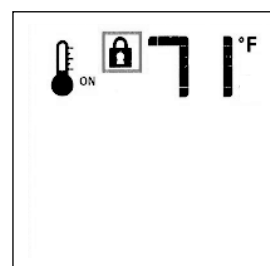

Fig. 15.17. Lock ON.

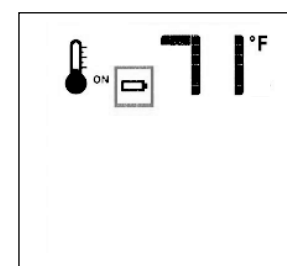

Fig. 15.18. Low Battery. See page 34.

16. Maintenance

NOTICE:

- **THIS APPLIANCE AND VENT SYSTEM MUST BE INSPECTED ANNUALLY BY A QUALIFIED GAS TECHNICIAN.** Keep this manual for reference.
- **IMPORTANT: ALWAYS TURN OFF THE GAS SUPPLY AND DISCONNECT POWER FROM THE APPLIANCE BEFORE ANY SERVICE WORK IS PERFORMED.**

GLASS AND SAFETY SCREEN BARRIERS

- **DO NOT OPERATE THIS APPLIANCE IF ANY OF THE GLASS PANELS OR SAFETY SCREEN BARRIERS IS REMOVED, CRACKED, DAMAGED OR MISSING.**
- **REPLACE DAMAGED COMPONENTS USING ONLY GENUINE JØTUL PARTS AVAILABLE FROM ANY JØTUL AUTHORIZED DEALER. REPLACEMENT SHOULD BE DONE ONLY BY A LICENSED OR QUALIFIED SERVICE PERSON.**
- **CAUTION: HANDLE BROKEN GLASS WITH CARE. REMOVE THE LOG SET AND USE A VACUUM TO CLEAN ANY REMAINING GLASS FRAGMENTS FROM THE BURNER AND FIREBOX.**

Annual Cleaning

Vent System

- The entire vent system, including the chimney if appropriate, should be inspected every year. If the venting is disassembled for any reason, it should be reassembled and sealed according to the vent manufacturer's instructions provided at the initial installation. **DO NOT USE SILICONE SEALANT.**

Burner System

Periodically inspect the firebox, valve compartment, convection airways and optional blower to **BE CERTAIN THAT THE FLOW OF COMBUSTION AND VENTILATION AIR IS UNOBSTRUCTED.**

- The valve compartment should be vacuumed regularly to remove dust and debris. Vacuum more frequently if there are pets in the home.
- Use a soft brush attachment and handle log set components carefully.
- The pilot assembly and burner base should be inspected and cleaned annually by a qualified technician. Replace any component showing evidence of corrosion.

Glass Care

Clean the glass only when necessary. Wipe the surface with a clean, dampened, soft cloth. Follow with a dry, soft towel. Take care not to scratch the glass surface.

WARNING:

DO NOT USE ABRASIVE CLEANERS ON THE GLASS. NEVER CLEAN THE GLASS WHEN IT IS HOT. DO NOT USE AMMONIA-BASED CLEANING SOLUTIONS.

Glass and Gasket Inspection

It is important that the glass gasket be inspected at least annually. Examine the ribbon gasket for signs of deterioration and make sure the gasket has a positive seal. Replace the gasket if necessary. Refer to the replacement parts list on page 39.

NOTE: INSPECT THE GLASS SURFACE FOR SCRATCHES AS THESE CAN WEAKEN THE PANEL TENSILE STRENGTH. REPLACE THE PANEL IF ANY SCRATCHES ARE FOUND. USE ONLY DOOR GLASS KIT 158067 AND SIDE GLASS PANEL 158080. DO NOT SUBSTITUTE ANY OTHER TYPE OF GLASS.

Front Door Glass & Gasket Replacement Kit 158067

Tools: needle nose pliers

1. Lift and remove the Top Plate.
2. Use the Latch Tool to pull each latch hook forward to disengage them from the glass frame. Fig. 2.2, page 5.
3. Lift the glass frame up and off of the firebox.
4. The glass panel is held in place by four tabs at the frame corners. Use a screwdriver or small pliers to pry these up just enough to release the glass panel. See fig. 16.1, page 32.
5. Remove the old gasket material.
6. Wrap the new gasket material evenly around the edge of the glass, peeling back the protective strip to expose the adhesive as you go, leaving a 1/2" overlap at the top. Press the adhesive side down onto the glass surface. Do not stretch the gasket.
7. Place the gasketed glass within the frame and carefully bend each of the corner retainer tabs back just enough to secure the glass in the frame. The Replacement Glass kit includes 4 Tinnerman compression clips for use in case a tab should break. The clips engage over the edge of the frame sides.

Side Glass & Gasket Replacement Kit 158080

Read through these instructions before beginning the procedure.

Tool List:

- 10mm and 13mm sockets
- 24-in socket extension / small ratchet wrench

Replace the Side Glass Panel

1. Lift off the Top Plate. The collar grates are also loose.
2. **Open the firebox.** Use the Latch Tool to pull each latch hook forward to disengage the glass frame from the firebox. Lift the glass frame up and off of the stove.
3. Open the Control Panel under the firebox. **Loosen the Air Shutter wing nut** located below the firebox floor and push the stem back far as it will travel. See fig. 7.1, page 15.
4. **Remove the Burner:** Lift the front of the burner base to disengage it from the support brackets and pull it forward off of the burner injector. Then tilt it side-to-side and pull it out through the door opening. Fig. 7.2, page 15.
5. **Remove the Exhaust Baffle**, (#10, fig. 17.2) from the firebox with removal of two, 10 mm hex nuts, #11. See also Fig. 7.3, page 16.
6. **Remove the Glass Panel:**
 - Remove the M6 hex bolt from the upper bracket strap at the top of the firebox. Fig. 16.2.
 - Refer to fig. 16.3 and fig. 17.2 to locate the M8 hex bolt, #7, that attaches the cast iron Side Plate to the stove Base Plate, #40.
 - Use the 13 mm socket with 24-inch extension to loosen, **but not remove**, the M8 hex bolt. Loosen the bolt enough to tilt the side plate out from the firebox to access the two M6 nuts, #11, on the outside of the firebox.
 - Use the 10 mm socket to remove the upper and lower outside M6 glass frame nuts.
 - **From inside the firebox**, locate and remove the upper and lower remaining M6 glass frame nuts, #11, Fig. 17.3.
 - Remove the glass panel and frame from the firebox.

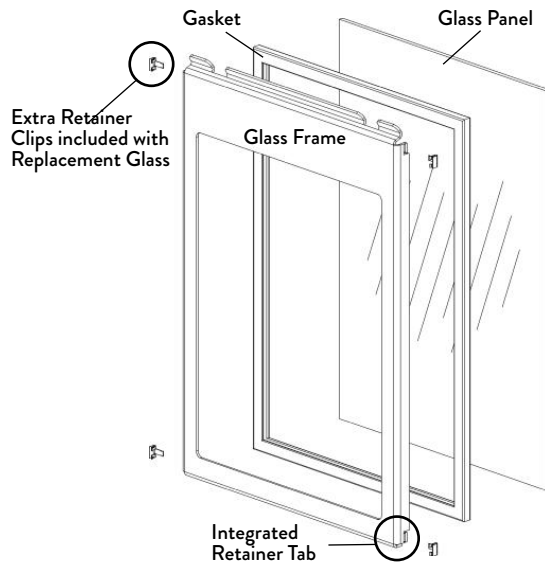

Figure 16.1.
Front Glass replacement.



Figure 16.2. Remove the firebox-to-side plate bolt.

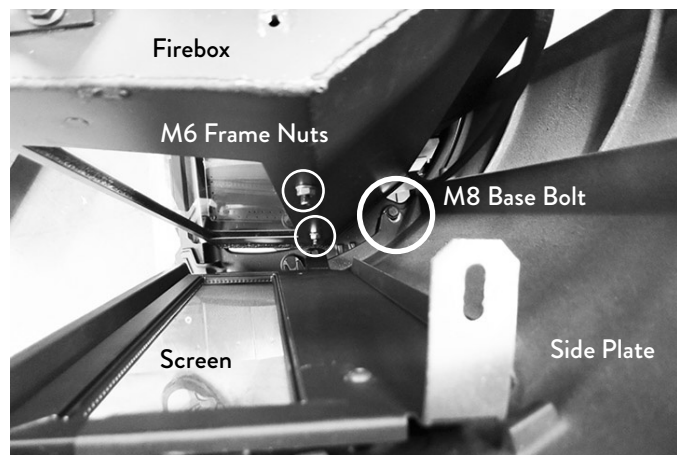

Figure 16.3. View down between firebox and side plate: Loosen the M8 Base bolt and tilt the Side Plate back to remove the M6 glass frame nuts.

7. Install replacement side glass and gasket:

- Wrap the new gasket material evenly around the edge of the glass, peeling back the protective strip to expose the adhesive, leaving a 1/2" overlap at the end seam. Press the adhesive side down onto the glass surface. Do not stretch the gasket.
- Place the panel within the frame and reinstall it in the firebox using the four M6 nuts previously removed.

8. Adjust the Side Plate position to evenly align the rear edge seam with the opposite side plate and retighten the base bolt.**9. Re-attach the upper bracket strap to the firebox using the original M6 hex bolt.****10. Replace the Exhaust Baffle and Burner assembly.**

- Readjust and tighten the air shutter following the guidelines in Section 14, Air Shutter Adjustment on page 24.

11. Replace the front Front Glass Frame, and Top Plate.

Safety Screen Maintenance and Replacement

Cleaning

The integrated, Invisimesh® safety screens, located in front of the door and side glass panels, should be periodically cleaned to remove dust, lint, and other air-bourne debris. Over time, and with continuous exposure to heat, these materials can contribute to variations in the screen hue.

Open the front door and clean both sides of the screen using a fine, soft bristle brush or vacuum attachment.

APPLY ONLY VERY GENTLE PRESSURE TO AVOID DAMAGING THE SCREEN.

225950 Front Safety Screen Replacement

Tools: #4 hex key

The front safety screen is easily accessible from the back of the door.

Use a #4 Hex Key to remove the four button head screws and retainer brackets as shown in fig. 16.4.

The replacement screen and frame installs as a single unit using the original four brackets and screws.

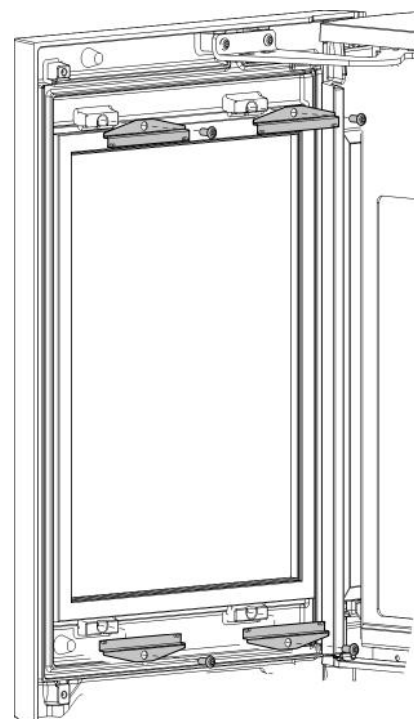

*Figure 16.4.
Remove front screen
retainer screws and
brackets.*

Side Safety Screen Replacement Kit 158063

Read through these instructions before beginning the procedure.

Tool List:

- 13mm socket
- 24-in socket extension / small ratchet wrench
- #4 hex key

The side screens are secured to the side plates by a steel bracket, #5, fig. 17.2, page 36, which must first be loosened to remove the screen frame.

1. Remove the Top Plate
2. Remove the M6 bolt, #11, from the upper bracket strap at the top of the firebox. Fig. 16.2.
3. Tilt the Side Plate away from the firebox enough to remove only the two **upper** button head screws, #6, from the Screen Bracket, fig. 16.5. There is no need to remove the lower screws.
4. Tilt the screen bracket back enough to lift the screen frame up and out.
5. Reverse the procedure to re-install the new screen.

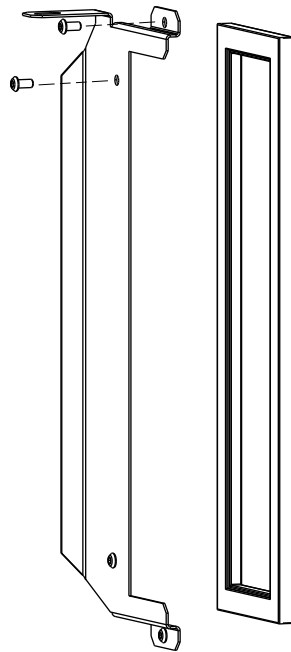

Figure 16.5.
Remove the two upper
button head screws
only.

Remote Transmitter Battery Replacement

The life-span of hand-held transmitter batteries depends upon battery quality, the frequency of set point changes, frequency of ignition call changes, etc.

When battery power is low, a Battery icon will appear on the transmitter display before all power is lost. See fig. 15.18, page 30. The icon will disappear with installation of three, fresh AAA batteries.

NOTE: Avoid inadvertently pressing the thermostat function key when replacing the batteries. Doing so will turn off thermostatic functions. To restore that function, re-install the batteries while again pressing the thermostat key.

Receiver Battery Replacement

A red LED on the IFC board indicates low battery power.

1. Disconnect electrical power from the appliance.
2. Remove the cast iron overlay.
3. The battery box located in the right side control compartment. Slide the two battery cover sliders outward to open the box. Pull out the battery holder. Install four new AA batteries noting the polarity indicated on the front of the box. Insert the battery holder and slide the battery cover sliders inward to lock.
4. Reconnect power to the stove.

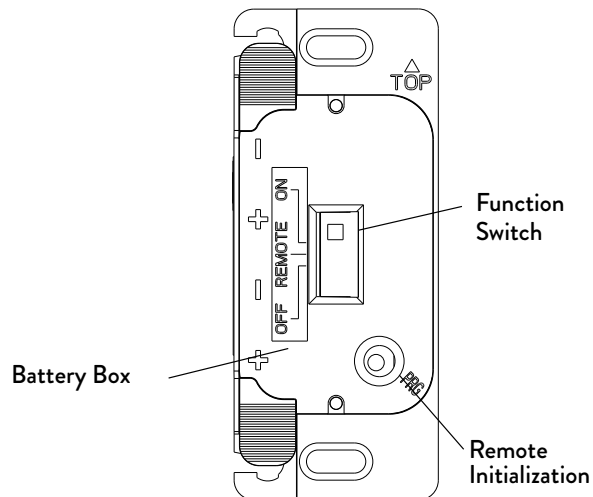

Figure 16.6. Receiver battery replacement.

17. Appendix

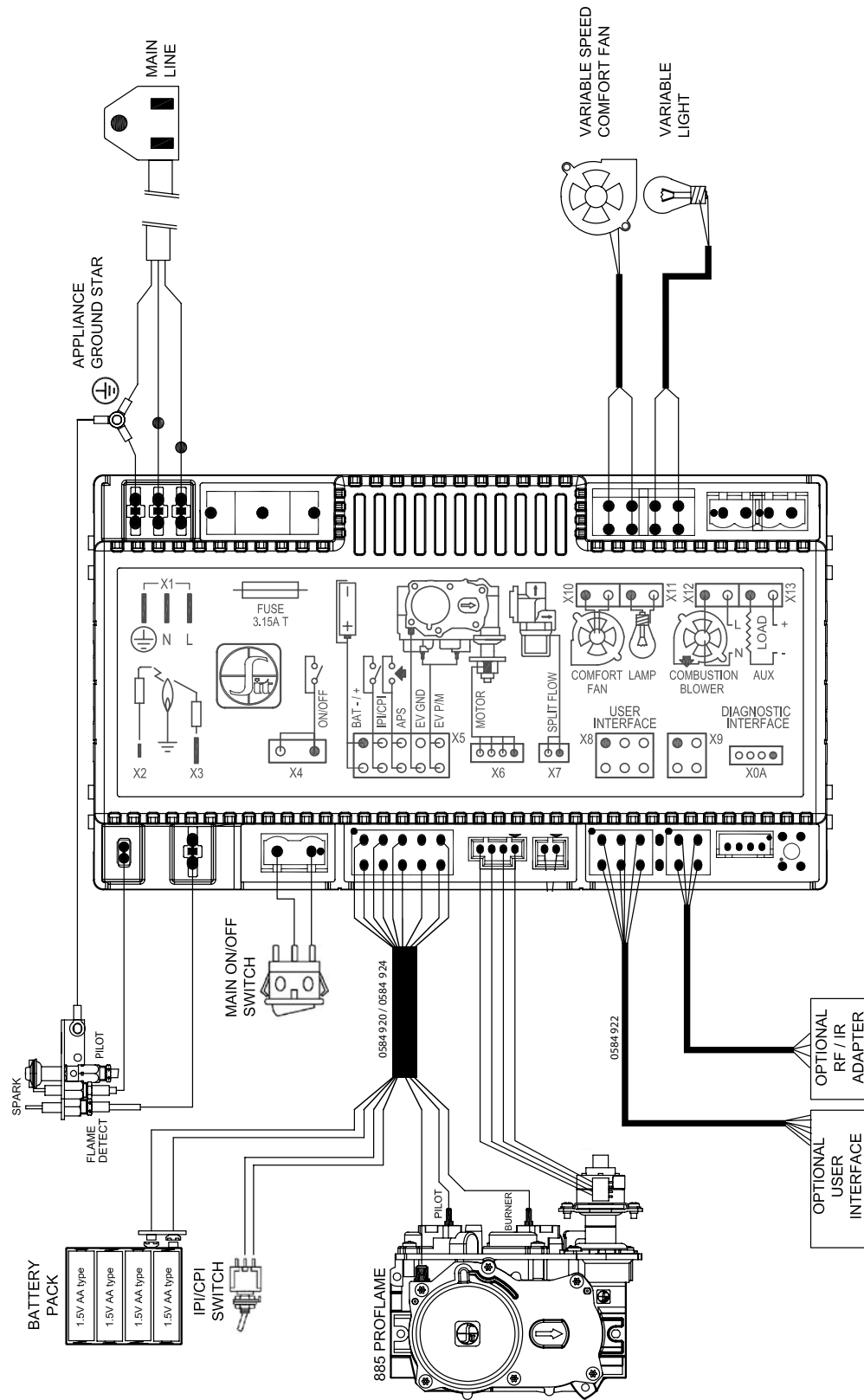

Figure 17.1 GF 160 DV IPI Proflame 2 Wiring Schematic including Premium Upgrade components

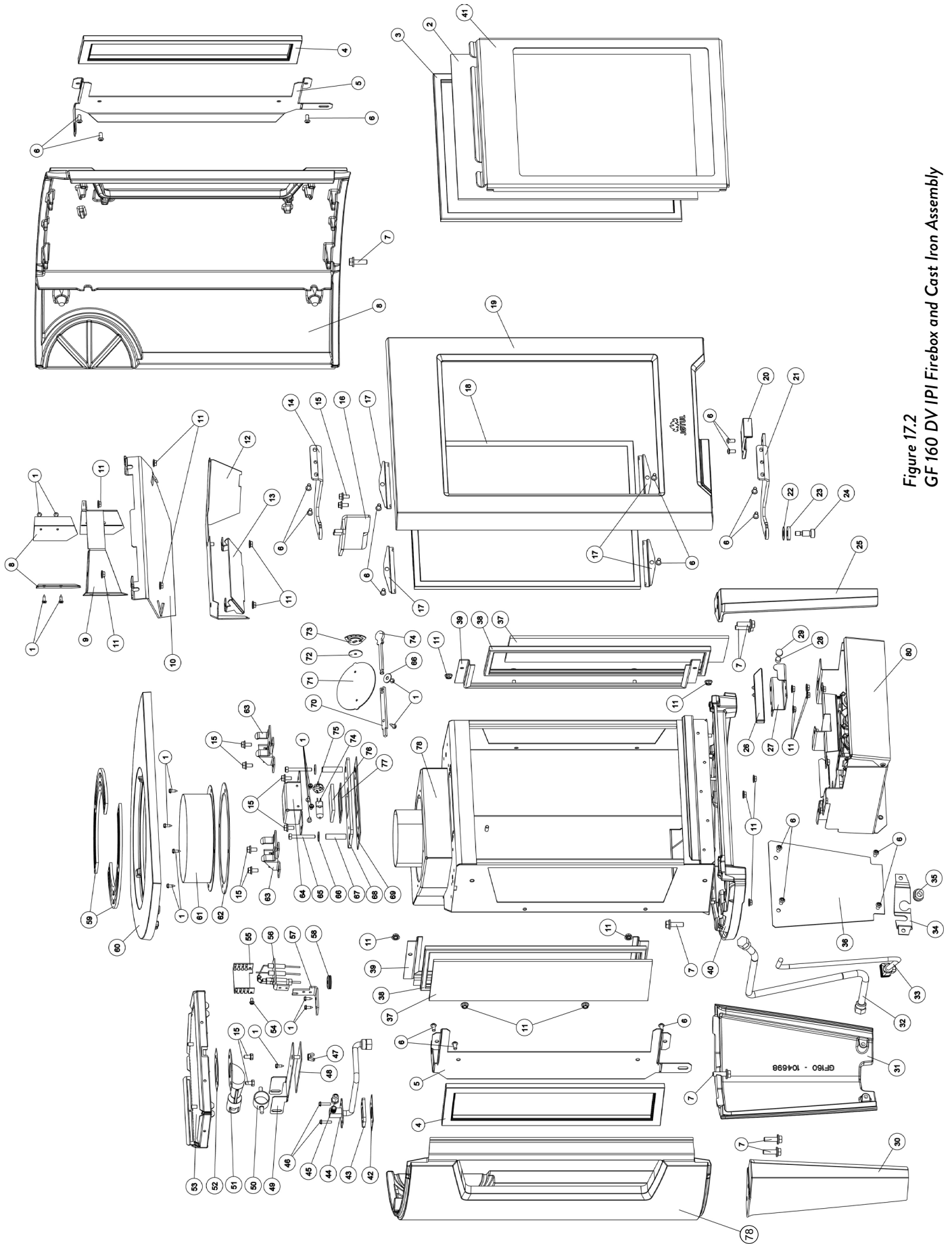

Figure 17.2
GF 160 DV IPI Firebox and Cast Iron Assembly

| No. | Part No. | Description |
|-----|----------|--|
| 1. | 117917 | Screw, #8 x 1/2" SM Blk Oxide |
| 2 | 158067 | Glass, Ceramic, Front, 5mm (.197") |
| 3 | 129124 | Gasket, Tadpole, .25 X 1.25 I, Graphite, Self Adhesive |
| 4 | 225952 | Screen Assembly, Side |
| 5 | 22595392 | Retainer, Side Screen - MB |
| 6 | 118034 | Bolt, M6 x 12 Button Head Socket |
| 7 | 117876 | Bolt, M8 x 25, Hex Serr Flng Hd, Class 8.8, Blk Oxid |
| 8 | 10480292 | Side Plate, Right, Matte Black Paint |
| | 10480254 | Side Plate, Right, Linen Enamel |
| 9 | 226249 | Baffle Wing |
| 10 | 22603392 | Exhaust Baffle - Matte Black |
| 11 | 117968 | Nut, M6 Serrated Flange plain |
| 12 | 22603292 | Burner Skirt, - Matte Black |
| 13 | 226260 | Air Deflector, Under Skirt |
| 14 | 22603492 | Door Hinge, Upper - Matte Black |
| 15 | 117130 | Bolt, Hex Head Serr Flange M6x12 Blk |
| 16 | 22603592 | Bracket, Door Hinge Upper - Matte Black |
| 17 | 12601192 | Glass Clip w/o gasket - Matte Black |
| 18 | 225950 | Screen Assembly, Front |
| 19 | 158069 | Door, Matte Black Paint |
| | 158360 | Door, Linen Enamel |
| 20 | 10482392 | Handle, Primary Air - Matte Black |
| 21 | 22625892 | Door Hinge, Lower - Matte Black |
| 22 | 117587 | Washer, Door Handle, M6 X 18mm OD x 1.6mm |
| 23 | 226213 | Spacer, Door Hinge, .188" |
| 24 | 118239 | Screw, Shoulder, M8x13 Thd, 10mmx16mm SHldr, |
| 25 | 10481492 | Leg, Right - Matte Black |
| | 10481454 | Leg, Right - Linen Enamel |
| 26 | 10482292 | Door Filler - Matte Black |
| | 10482254 | Door Filler - Linen Enamel |
| 27 | 22603892 | Bracket, Door Handle - Matte Black |
| 28 | 225338 | Magnet, .375" Dia x .25", Neo High Temp |
| 29 | 224909 | Cap, Silicone, .375" ID x .250" DP |
| 30 | 10481292 | Leg, Left - Matte Black |
| | 10481254 | Leg, Right - Linen Enamel |
| 31 | 10469892 | Rear Leg - Matte Black |
| | 10469854 | Rear Leg - Linen Enamel |
| 32 | 226310 | Flex tube, 36" x 3/8 OD Gas Supply |
| 33 | 157492 | Replacement Power Cord Ass'y, Proflame 2 IPI |
| 34 | 22606892 | Retainer, Electric & Gas Supply - Matte Black |
| 35 | 117951 | Wire Strain Relief, Heyco 7P-2 (Large) |
| 36 | 22605092 | Rear Cover, Supply Lines - Matte Black |
| 37 | 158080 | Glass, Ceramic, Side, 5mm (.197") INC. Gasket, #38 |
| 38 | 225961 | Gasket, Woven Tape, .187" x .750" |
| 39 | 22595492 | Retainer, Side Glass - Matte Black |

| No. | Part No. | Description |
|-----|----------|---|
| 40 | 158068 | Base Plate - Matte Black |
| | 158361 | Base Plate - Linen Enamel |
| 41 | 22595192 | Glass Frame - Matte Black |
| 42 | 222280 | Gasket, Drop In Orifice Holder |
| 43 | 226247 | Shim, Drop in Orifice Holder |
| 44 | 223231 | Orifice Holder, Drop In Assembly, 12.5" Tube |
| 45 | 226255 | Orifice, 2.45mm, NG |
| 46 | 117986 | Screw, #8 X 3/4 SL HWH SMA ZINC |
| 47 | 117975 | Nut, Wing M6 Zinc |
| 48 | 226263 | Gasket, Shutter Handle, GF 160 DV IPI |
| 49 | 226054 | Handle, Air Shutter, GF 160 DV IPI IPI |
| 50 | 224903 | Air Shutter Ass'y, .75" Window |
| 51 | 157604 | Venturi Weldment, inc. w/ #53 |
| 52 | 224790 | Burner Gasket, inc. w/ #53 |
| 53 | 158071 | Replacement Burner Assembly |
| 54 | 117999 | Screw, SL SMA Type B #8 x 3/8 Zinc |
| 55 | 226262 | Pilot Shield, GF160 DV IPI |
| 56 | 158222 | Pilot Assembly, NG, Ang Brkt, SS Body, 24" Wires, IPI |
| 57 | 226238 | Bracket, Pilot Mount GF160 DV IPI |
| 58 | 225525 | Grommet, Silicone, Pilot Plug, GF500 |
| 59 | 22299592 | Top Grill, 2 - Matte Black |
| 60 | 158072 | Top Plate - Matte Black |
| | 158362 | Top Plate - White Enamel |
| 61 | 129322 | Adapter Pipe, 6.625 dia |
| 62 | 129118 | Gasket, Starter |
| 63 | 22009192 | Latch, Glass Frame / MB |
| 64 | 224763 | Light Box, Delay Door Mount |
| 65 | 9911 | Bolt, Hex Cap, M6x45, DIN 933, Class 8.8, Blk |
| 66 | 120004 | Washer, Fender, 6.4mm ID x 18mm OD |
| 67 | 118267 | Sleeve, .375" OD x .312" OD x 1.50", Steel |
| 68 | 22602892 | Delay Door - Matte Black |
| 69 | 226070 | Gasket, Relief Door, GF 160 DV IPI |
| 70 | 226026 | Inner Rod, Exhaust Restrictor, GF 160 DV IPI |
| 71 | 226025 | Exhaust Restrictor Plate, GF 160 DV IPI |
| 72 | 223241 | Gasket, Exhaust Restrictor |
| 73 | 22602492 | Washer, Exhaust Restrictor - Matte Black |
| 74 | 22602792 | Outer Rod, Exhaust Restrictor - Matte Black |
| 75 | 157601 | Replacement, IPI Light Holder Harness |
| 76 | 222974 | Glass, Ceramic, Light Fixture |
| 77 | 222977 | Gasket, Light Cover |
| 78 | 10480392 | Side Panel, Matte Black Paint |
| | 10480354 | Side Panel, Linen Enamel |

GF 160 DV IPI Illustrated Parts Breakdown

Use only parts available from
Jetul authorized dealers.

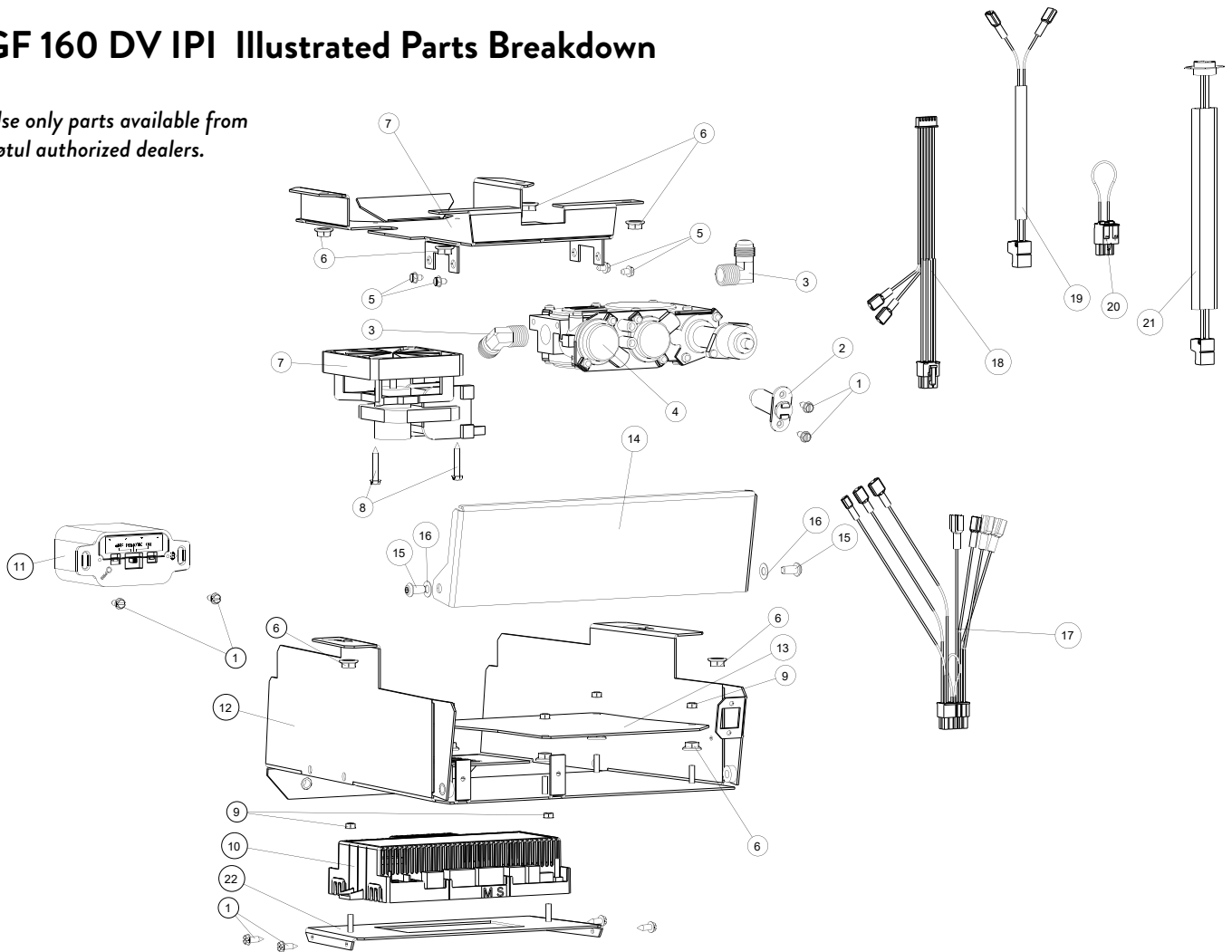

Figure 17.3
GF 160 DV IPI Valve Assembly and IFC Components.

| No. | Part No. | Description |
|-----|----------|--|
| 1. | 117917 | Screw, #8 x 1/2" SM Blk Oxide |
| 2. | 224145 | Magnetic Door Catch, Push Release |
| 3. | 222292 | Elbow, 90°, Bass 3/8" x 3/8" |
| 4. | 222922 | Valve, NG - 30% TD, SIT .885.001 w/Motor |
| 5. | 118214 | Screw, #8 x 1/4", Taptite, SLHWH |
| 6. | 117986 | Nut, M6 Serr. Flange Hd |
| 7. | 223227 | Blower, Axial, 40 CFM, 120V |
| 8. | 118095 | Screw, #8 x 1" HWH SM |
| 9. | 118055 | Kepton, M4, Ext. Tooth, Lockwasher |
| 10. | 158130 | Proflame 2 IFC Control Board (POD) |
| 11. | 158006 | Replacement, Proflame 2 Battery Box |
| 12. | 226048 | Controls Cover |
| 13. | 226294 | Rating Plate Bracket |
| 14. | 22605992 | Control Door, Matte Black |
| 15. | 118034 | Bolt, M6 x12 Button Hd Socket |
| 16. | 117588 | Washer, Hinge - M6 - 12mm OD x 6mm ID |

| No. | Part No. | Description |
|-----|------------|---|
| 17. | 158065 | Replacement Valve Harness |
| 18. | 158064 | Replacement Switch Harness |
| 19. | 158066 | Replacement Blower Wire Harness |
| 20. | 158053 | Replacement Proflame 2 ON/OFF (x4) Jumper |
| 21. | 157601 | Replacement 2 Bulb Holder |
| 22. | 226429 | IFC Mounting Plate |
| 23. | 157492* | Replacement Power Cord Ass'y. IPI |
| 24. | 157711* | Replacement IPI Wire Harness |
| 25. | 157601* | Replacement Multifunction Remote / Black |
| 26. | 223951BKP* | Replacement Remote Wall Bracket / Blk PCt |
| 27. | 157494* | Replacement Burner Control Wire Harness |
| 28. | 226568* | Blower Shield |

*not illustrated

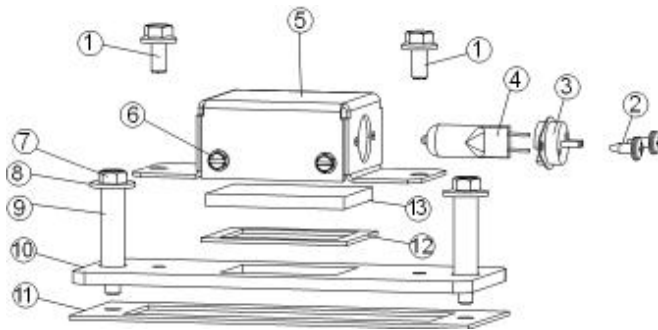

Figure 17.4
GF 160 DV IPI Accent Lamp Assembly

| No. | Part No. | Description |
|-----|----------|--|
| 1. | 117130 | Bolt, Hex Hd Serr Flange M6 x 12 Blk |
| 2. | 117967 | Screw, Pan Hd #7 x 3/8 PH |
| 3. | 157601 | Replacement Light Fixture, High-Temp, |
| 4. | 224943 | Light Bulb, 130 Volt, 35 Watt |
| 5. | 22476392 | Light Box, Delay Door Mount, MB |
| 6. | 117917 | Screw, #8 x 1/2" SM |
| 7. | 9911 | Bolt, Hex Cap, m6 x 45mm Blk |
| 8. | 120004 | Washer, Fender, 6.4mm ID x 18mm OD x 1.6mm |
| 9. | 118267 | Sleeve, .375" OD x .312" OD x 1.50" |
| 10. | 22602892 | Delay Door, MB |
| 11. | 226070 | Gasket, Delay Door |
| 12. | 222977 | Gasket, Light Cover |
| 13. | 222974 | Glass, Ceramic, Light Fixture |

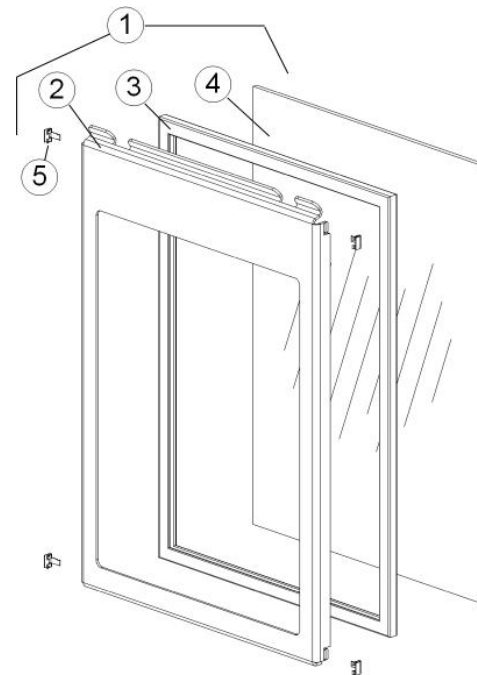

Figure 17.5
GF 160 DV IPI Glass Assembly

| No. | Part No. | Description |
|-----|----------|--|
| 1. | 158067 | Replacement Glass Kit, GF 160 DV IPI Does not include #2, Steel Glass Frame |
| 2. | 220042 | Tinnerman Retainer Clips, 4 |
| 3. | 129124 | Gasket, Tadpole - .25" x 1.25", 7ft. |
| 4. | 225959 | Glass Panel, Ceramic - 5 mm |
| 5. | 22595192 | Glass Frame 220042 |

GF 160 Optional Panel Replacement Parts

Replacement Firebox Panel Parts

| | | |
|----|--------|-------------------|
| 1 | 226029 | Rear Panel |
| 2. | 226030 | Side Panel, L & R |

Replacement Black Reflective Glass Panel Parts

| | | |
|----|--------|------------------------------|
| 1 | 226073 | Reflective Rear Panel |
| 2. | 226074 | Reflective Side Panel, Right |
| 3. | 226075 | Reflective Panel, Left |

GF 160 Safety Screen Barrier Replacement

| | | |
|----|--------|-------------------|
| 1 | 158062 | Front Panel |
| 2. | 158063 | Side Panel, L & R |

Mobile Home Installation

The GF 160 DV IPI is approved for installation in a mobile home in the U.S. and Canada with the following requirements:

- The stove must be secured to the floor of the mobile home. Use Jotul Floor Bracket Kit 158074.
- Provision must be made to secure an electrical ground between the stove and the mobile home chassis. Use Jotul Floor Bracket Kit 158074.
- The stove must be installed in accordance with Title 24 CFR, Part 3280-Manufactured Home Construction and Safety Standard in the U.S.
In Canada, comply with CSA Z240.4, Gas Equipped Recreational Vehicles and Mobile Housing.
- Always contact your local officials about installation restrictions and requirements in your area.

THIS APPLIANCE MAY BE INSTALLED AS AN OEM INSTALLATION IN A MANUFACTURED (MOBILE) HOME AND MUST BE INSTALLED IN ACCORDANCE WITH THE MANUFACTURER'S INSTRUCTIONS AND THE MANUFACTURED HOME CONSTRUCTION AND SAFETY STANDARD, TITLE 24 CFR, PART 3280. THIS APPLIANCE IS ONLY FOR USE WITH THE TYPE OF GAS THAT IS INDICATED ON THE STOVE'S RATING PLATE. A GAS CONVERSION KIT IS PROVIDED WITH THE GF 160 DV IPI GAS STOVE.

THIS APPLIANCE MAY BE INSTALLED IN AN AFTERMARKET PERMANENTLY LOCATED, MANUFACTURED (MOBILE) HOME, WHERE NOT PROHIBITED BY LOCAL CODES.

Leg Bracket Kit #158074

Kit Contents:

- Leg Bracket, Two

Tools & Materials:

- Power Drill / Drill Bit
- Adjustable wrench
- Lag Screw or similar fastener appropriate for the floor construction
- Grounding wire and chassis clamp

Procedure

1. In compliance with local electrical code, install a ground wire from the mobile home grounding to the stove rear leg location.
2. Loosen the lower Cover Plate bolts on the rear stove leg and engage each kit floor bracket with the bolt head. See Fig. 17.7
3. Mark the bracket bolt hole locations on the floor and drill floor fastener holes at those locations.
4. The ground connection may be made at either a cover plate bolt or floor bolt.
 - Secure the floor brackets to the floor with appropriate fasteners.
 - Tighten the cover plate bolts to secure the floor brackets to the stove.

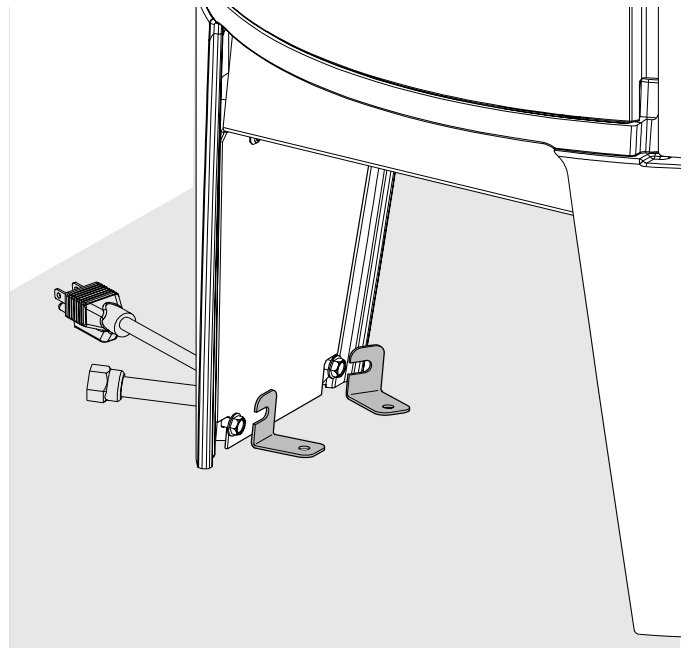

Figure 17.6
Floor Bracket installation.

Burner Reference Flame Patterns



Figure 17.7 *Rock Set flame pattern*



Figure 17.8 *Tumbled Stone flame pattern*



Figure 17.9 *Fire Glass flame pattern*

Beach Fire Logset 158229

Installation Instructions

CAUTION !
 Ceramic fiber log surfaces are tender and can be easily chipped or scratched.
USE GLOVES AND HANDLE THE LOGS WITH CARE.

Installation

Carefully unpack and inspect the contents. Immediately report any damage to your Jøtul authorized dealer.

DO NOT INSTALL DAMAGED COMPONENTS.

Contents:

- 1 Adaptor Plate
- 2 Rear Log
- 3 Center Log
- 4 Front Log
- 5 Left Vertical Log
- 6 Right Vertical Log
- 7 Ember Stones, 4 oz.

Tools Required:

- safety gloves
- safety goggles

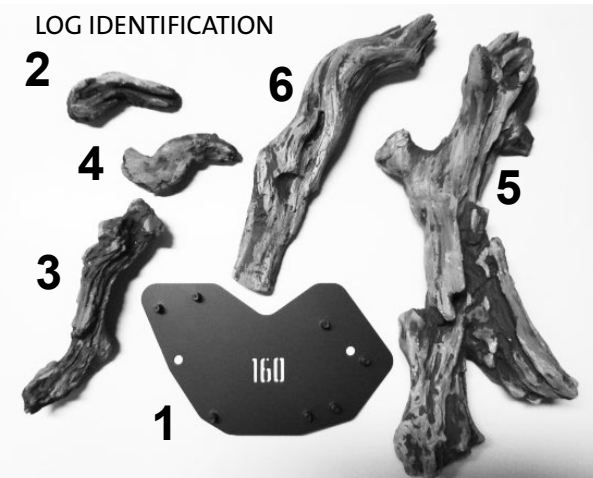

1. Refer to the Contents list and lay out the logs to identify the parts as shown. The logs engage with steel pins on the Adaptor Plate (1). Identify pin engagement holes in the underside of logs 2, 3, and 4. Engagement holes are in the lower ends of logs 5 and 6.

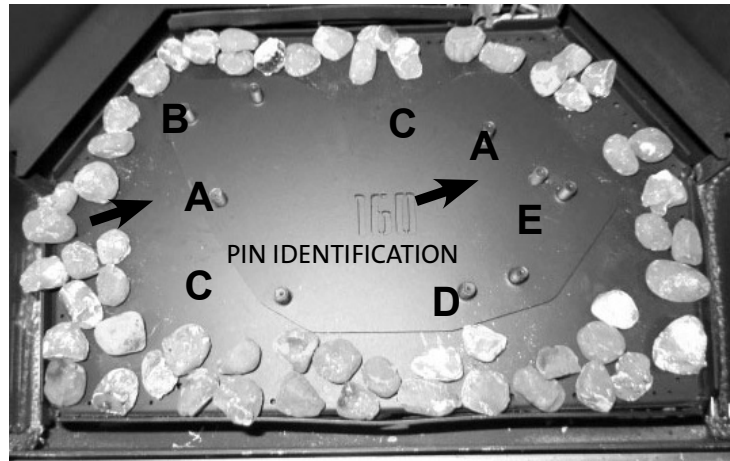

2. Install the Adaptor Plate (#1) on the burner by engaging it with the two burner pins (A) at the arrows shown above.
3. Loosely spread a layer of ember stones around the perimeter of the burner plate.

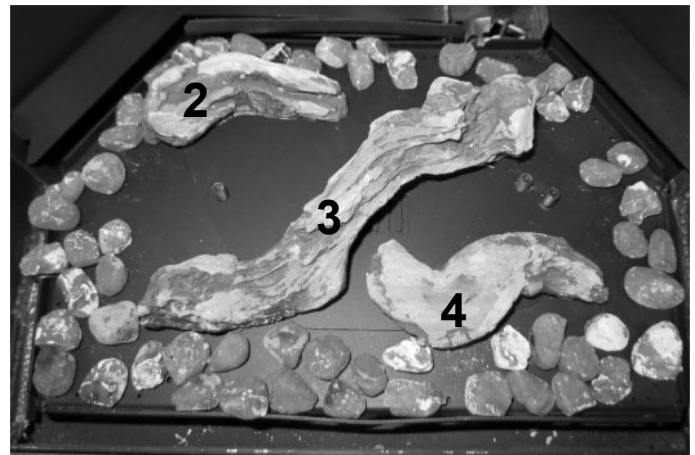

4. Engage the holes in the bottom of Rear Log (#2) with the two steel pins (B) at the left rear corner of the burner plate.
5. Engage the two holes in the bottom of the Center Log (#3) with the two burner plate pins (C).
6. Engage the holes in the Front Log (#4) with the two pins (D) in the right front corner.



7. Engage the hole at the lower end of the Left Vertical log (#5) with left Adaptor pin "A". See Step 2 photo.

Vertical log (#6) with pin "E" on the Adaptor plate.

Rest the upper end against the depression on the log #5 as shown.

8. Engage the hole at the lower end of the Right

18. Jøtul Gas Product Warranty

This warranty policy applies to gas products identified by the Jøtul trade name as set forth below.

A. LIMITED FIVE YEAR WARRANTY - Cast Iron, Steel Doors, Surround Components, Firebox:

Jøtul North America Inc. (JØTUL) warrants, to the original retail purchaser, that those components of the Jøtul Gas Stove or Fireplace specified above will be free of defects in material and workmanship for a period of five (5) years from the date of purchase. This warranty is subject to the terms, exclusions and limitations set forth in the following text.

B. LIMITED TWO YEAR WARRANTY - Burner, Ceramic Burner, Burner Treatments, Firebox Panels:

JØTUL warrants, to the original retail purchaser, that those components of the Jøtul Gas Stove or Fireplace specified above will be free of defects in material and workmanship for a period of two (2) years from the date of purchase. Ceramic burners are warranted against functional defects for a period of two (2) years from the date of purchase. This warranty is subject to the terms, exclusions, and limitations set forth in the following text.

C. LIMITED TWO YEAR WARRANTY - Enamel Finish:

JØTUL warrants, to the original retail purchaser, the enamel finish on cast iron components of the Jøtul Stove or Fireplace Insert specified above against peeling or fading for a period of two (2) years from the date of purchase. This warranty is subject to the terms, exclusions and limitations set forth below.

D. LIMITED ONE YEAR WARRANTY - Gas & Electrical Components (controls, plumbing, valve, blower):

JØTUL warrants, to the original retail purchaser, that those components of the Jøtul Gas Stove or Fireplace specified above will be free of defects in material and workmanship for a period of one (1) year from the date of purchase. This warranty is subject to the terms, exclusions, and limitations set forth in the following text.

JØTUL will repair or replace (including parts & labor), at its option, any of the above components determined by JØTUL to be covered by this warranty. You must, at your own expense, arrange to deliver or ship the component to an authorized Jøtul dealer and arrange for pickup or delivery of the component after repairs have been made. If, upon inspection, JØTUL determines that the component is covered by this warranty, the repair or replacement will be made as set forth above. This warranty is not transferable and is extended only to, and is solely for the benefit of, the original retail purchaser of the Jøtul Gas Stove or Fireplace. This paragraph sets forth the sole remedy available under this warranty in the event of any defect in the Jøtul Gas Stove or Fireplace. The warranty period for any replaced component will be the remaining unexpired portion of the warranty period for the original component. Please retain your dated sales receipt in your records as proof of purchase.

EXCLUSIONS AND LIMITATIONS

NOTICE: This warranty is void if installation or service is performed by someone other than an authorized installer, service agency or gas supplier, or if installation is not in conformance with the installation and operating instructions contained in this owner's manual or local and/or national fire and building regulations. A listing of local authorized installers, service agencies and gas suppliers can be obtained from the National Fireplace Institute at <http://www.nficertified.org/>.

This warranty does not cover the following:

- 1) Repair or replacement of parts that are subject to normal wear and tear during the warranty period or to parts that may require replacement in connection with normal maintenance. **These parts include lamp bulbs, paint, gaskets, and glass** (except to the extent such parts suffer damage from thermal stress).
- 2) Damage due to incorrect installations not in conformance with the installation instructions contained in this owner's manual or local and/or national fire and building regulations.
- 3) Damage due to service performed by an installer, service agency or gas supplier, unless otherwise agreed to in writing by JØTUL.
- 4) Labor or other costs associated with the repair of gas controls, plumbing, burners, log set, lamp bulbs, or sheet metal firebox beyond the warranty period.
- 5) Damage caused by unauthorized modification, use or repair.
- 6) Damage to enameled surfaces caused by improper operation or misuse, including use that is not in conformance with the operating instructions contained in this owner's manual. Such damage can typically be identified by bubbling, cracking, or discoloration of the enamel finish.
- 7) Costs incurred by travel time and/or loss of service.
- 8) Damage incurred while the Jøtul Gas Stove or Fireplace is in transit.

IN NO EVENT SHALL JØTUL, ITS PARENT COMPANY, SHAREHOLDERS, AFFILIATES, OFFICERS, EMPLOYEES, AGENTS OR REPRESENTATIVES BE LIABLE OR RESPONSIBLE TO YOU FOR ANY SPECIAL, INDIRECT, INCIDENTAL, CONSEQUENTIAL, PUNITIVE OR OTHER SIMILAR DAMAGES, INCLUDING, BUT NOT LIMITED TO, LOST PROFITS, LOST SALES, INJURY TO PERSON OR PROPERTY, OR DAMAGES TO A STRUCTURE OR ITS CONTENTS, ARISING UNDER ANY THEORY OF LAW WHATSOEVER. ALL IMPLIED WARRANTIES, INCLUDING THE IMPLIED WARRANTIES OF MERCHANTABILITY AND FITNESS FOR A PARTICULAR PURPOSE, OR OTHERWISE, ARE LIMITED IN DURATION TO THE LENGTH OF THIS WRITTEN WARRANTY. EXCEPT AS EXPRESSLY SET FORTH HEREIN, JØTUL MAKES NO ORAL, WRITTEN OR OTHER WARRANTY WITH RESPECT TO JØTUL GAS STOVES OR FIREPLACES.

Some states do not allow the exclusion or limitation of incidental or consequential damages, or limitations on the length of implied warranties. Therefore, the above exclusions or limitations may not apply to you. This warranty gives you specific legal rights, and you may have other rights, which vary from state to state. JØTUL reserves the right to discontinue, modify or change the materials used to produce the Jøtul Gas Stove or Fireplace. JØTUL shall have the right to replace any defective component with substitute components determined by JØTUL to be of substantially equal quality and price.

The dollar value of JØTUL's liability for breach of this warranty shall be limited exclusively to the cost of furnishing a replacement component. JØTUL shall not in any event be liable for the cost of labor expended by others in connection with any defective component. Any costs or expenses beyond those expressly assumed by JØTUL under the terms of this warranty shall be the sole responsibility of the owner(s) of the Jøtul Gas Stove or Fireplace.

No dealer, distributor, or other person is authorized to modify, augment, or extend this limited warranty on behalf of JØTUL. NO MODIFICATION OR CHANGE TO THIS WARRANTY WILL BE EFFECTIVE UNLESS IT IS MADE IN A WRITTEN DOCUMENT MANUALLY SIGNED BY AN AUTHORIZED OFFICER OF JØTUL.

An authorized installer may have been provided with certain information related particularly to the Jøtul Gas Stove or Fireplace; however, no authorized installer or other person who may service the appliance is an agent of JØTUL. No inference should be made that JØTUL has tested, certified, or otherwise pronounced any person as qualified to install or service the appliance. JØTUL shall not be liable or otherwise responsible for any error or omission by a person installing or servicing a Jøtul Gas Stove or Fireplace.

If you believe your Jøtul Gas Stove or Fireplace is defective, you should contact your nearest authorized Jøtul dealer, who will process a warranty claim. IN ORDER TO QUALIFY FOR WARRANTY COVERAGE, JØTUL MUST RECEIVE NOTICE OF A POSSIBLE DEFECT WITHIN SIXTY (60) DAYS OF THE DATE THE DEFECT IS FIRST DISCOVERED, OR REASONABLY COULD HAVE BEEN DISCOVERED.

This warranty is given by Jøtul North America, Inc.,
55 Hutcherson Drive, Gorham, Maine 04038 USA

LIGHTING INSTRUCTIONS

FOR YOUR SAFETY, READ BEFORE LIGHTING.

WARNING:

IF YOU DO NOT FOLLOW THESE INSTRUCTIONS EXACTLY, A FIRE OR EXPLOSION MAY RESULT CAUSING PROPERTY DAMAGE, PERSONAL INJURY, OR LOSS OF LIFE.

- A. This appliance is equipped with an ignition device which automatically lights the pilot. **Do Not** try to light the pilot by hand.
- B. **BEFORE LIGHTING**, smell all around the appliance area for gas.
Be sure to smell next to the floor because some gas is heavier than air and will settle to the floor.
- WHAT TO DO IF YOU SMELL GAS:**
- Extinguish any open flame
 - Open windows.
 - Do not light this or any other appliance.
 - Do not touch any electrical switches.
 - Do not use any phone in your building.
 - Immediately call your gas supplier from a neighbor's phone.
 - If your gas supplier cannot be reached, call the fire department.
- C. Use only your hand to turn the gas control knob. Never use tools. If the knob will not turn by hand, do not try to force it or repair it.
Call a qualified technician. Force or attempted repair may result in a fire or explosion.
- D. Do not use this appliance if any part has been under water. Immediately call a qualified service technician to inspect the appliance and to replace any part of the control system and any gas control which has been under water.

OPERATING INSTRUCTIONS

1. STOP! Read the safety information above.
2. Set the thermostat, if equipped, to the lowest setting.
3. Set the Burner switch to the "OFF" position.
4. This appliance is equipped with an ignition device which automatically lights the pilot. Do **not** try to light the pilot by hand.
5. Wait five (5) minutes to clear out any gas. Then smell for gas, including near the floor.
If you smell gas, STOP! Follow "B" in the safety information above on this label. If you do not smell gas, go to the next step.
6. Set the Mode switch to ON for continuous pilot operation. The pilot will light and automatically extinguish after seven days if there is no call for heat during that period. It will automatically re-ignite at the next call for heat.

OR

Set Pilot to REMOTE for hand-held transmitter control or thermostatic operation. The pilot will light only when there is a call for heat.

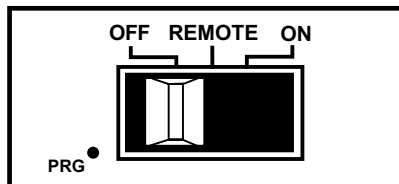

MODE SWITCH

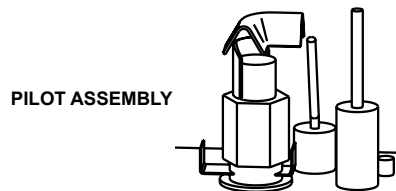

PILOT ASSEMBLY

7. Set the remote transmitter to the desired setting to light the burner. If the appliance will not operate, follow the instructions below "To Turn Off Gas To The Appliance" and call your service technician or gas supplier.

TO TURN OFF GAS TO THE APPLIANCE

1. Set the thermostat to the lowest setting.
2. Turn off all electric power to the appliance if service is to be performed.
3. Set the Mode switch to the "OFF" position.
4. Close control access door.

This page is intentionally left blank.

This page is intentionally left blank.

September 2022
139894_Rev. 6

This appliance must be installed in conformance with local and national building regulations. Before beginning the installation, it is important that these instructions be carefully read and understood. Jøtul maintains a policy of continual product development. Consequently, products may differ in specification, color or type of accessories from those illustrated or described in various publications.

Your stove has a unique serial number stamped on the rating plate located in the control compartment. Please record the serial number in the space below. You may also wish to attach your purchase receipt to this page for future reference.

MODEL NAME: Jøtul GF 160 DV IPI

SERIAL NUMBER: _____

DATE OF PURCHASE: _____

AUTHORIZED DEALER: _____

ADDRESS _____

PHONE: _____

INSTALLER: _____

FUEL TYPE: _____

FUEL CONVERSION: NO _____ YES _____

INSTALLATION DATE: _____

INSTALLATION TECHNICIAN: _____

Jøtul North America
55 Hutcherson Dr.
Gorham, Maine 04038-2634

Jøtul ASA
P.O. Box 1411
N-1602 Fredrikstad
Norway

